

Microfluidics Part 2 – Basic Fluid Mechanics

Prof. Steven S. Saliterman, <http://saliterman.umn.edu/>

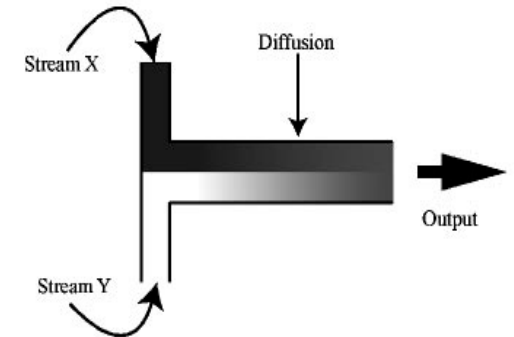
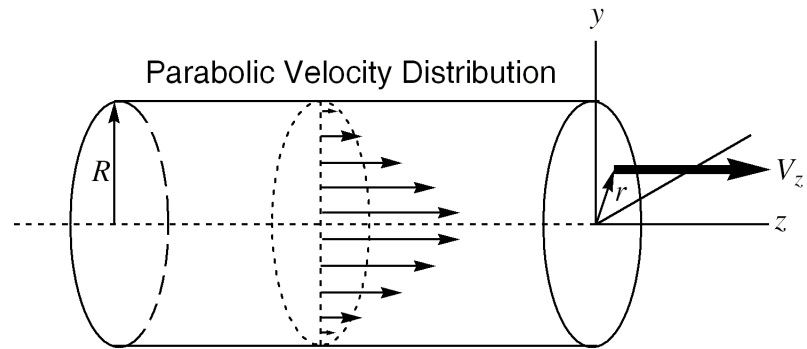
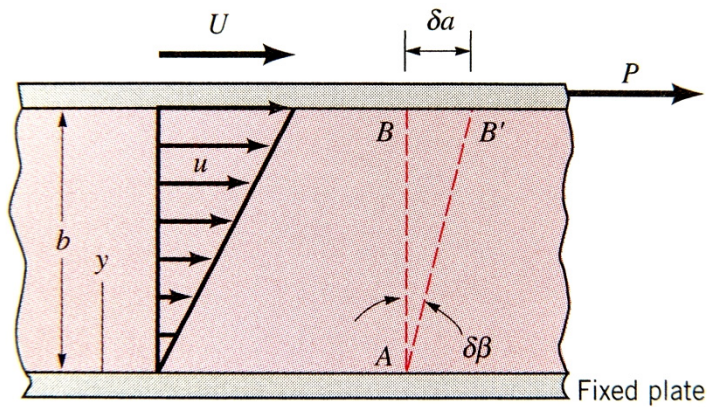

Topics

- Length & volume in the micro realm.
- Clinically relevant analyte concentrations.
- Sample volume determination.
- Fluid mechanics
- Surface area to volume
- Diffusion

Length & Volume Comparisons

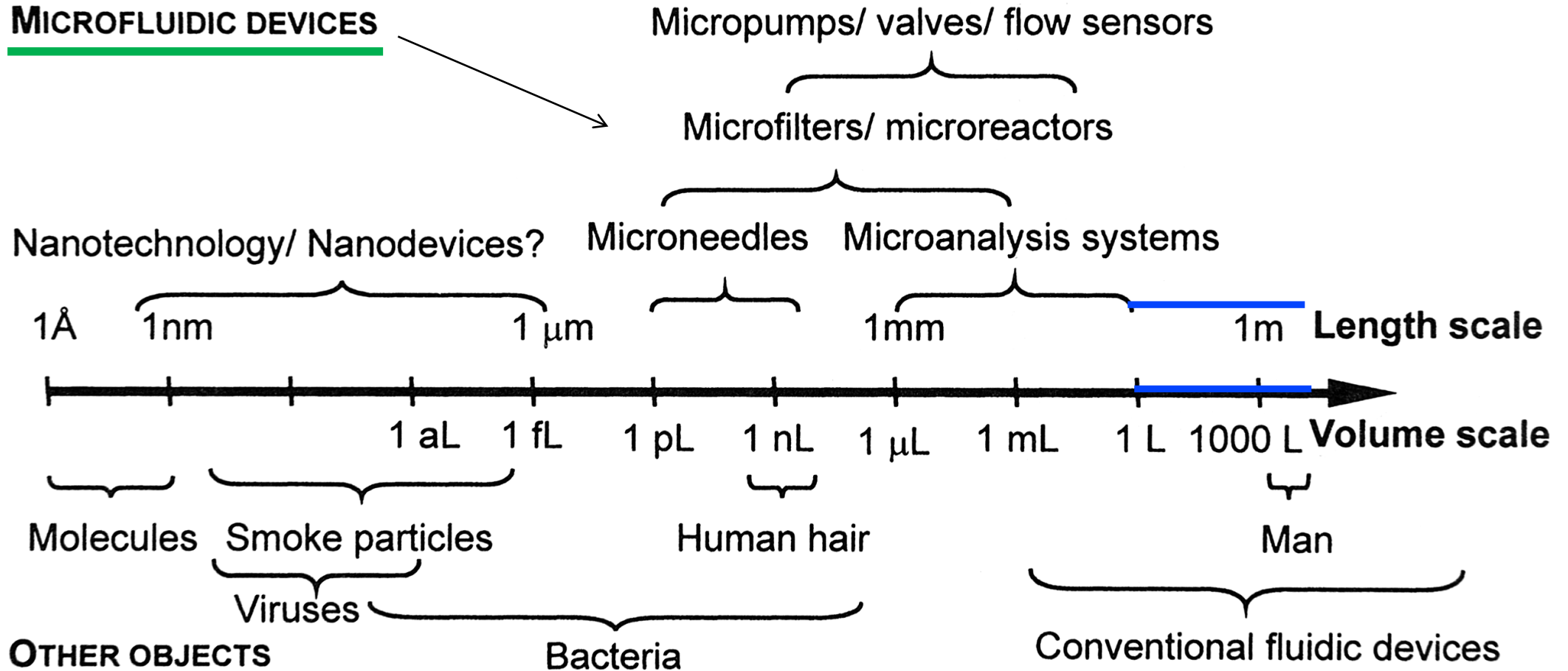

Typical Serum Analyte Concentrations...

DNA

Electrolytes

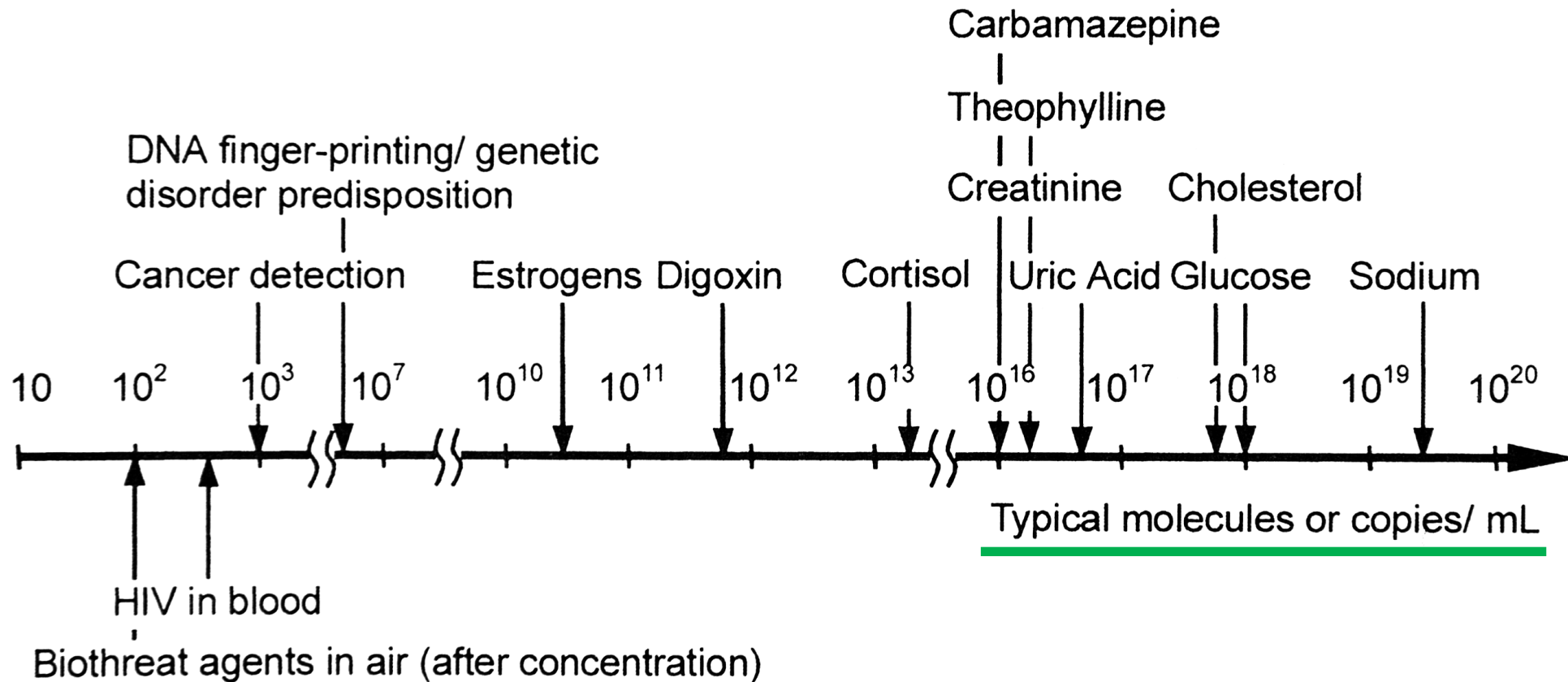

Determining Sample Volume

- The relationship between sample volume (V) and analyte concentration is shown here:

$$V = \frac{1}{\eta_s N_A A_i},$$

where

η_s (eta) is the sensor efficiency $0 \leq \eta_s \leq 1$,

N_A is 6.02×10^{23} , or Avogadro's number, and

A_i is the concentration of analyte, i .

- The higher the concentration of analyte and/or better the sensor, *the less the volume of sample* that is needed.

Example: K^+ (Potassium) in Serum

Potassium has a **concentration** of 3.5 to 5.3 mmol/liter in serum. Assume a sensor efficiency of 0.1, and concentration of 3.5 mmol/liter, approximately what is the smallest **volume** needed:

$$\begin{aligned} \text{Volume} &= \frac{1}{.1 \times \frac{6.02 \times 10^{23}}{\text{mole}} \times \frac{3.5 \times 10^{-3} \text{mole}}{\text{liter}}} \\ &= \frac{1 \text{ liter}}{2.1 \times 10^{20}} \\ &= .47 \times 10^{-20} \text{ liter} \end{aligned}$$

Sample Requirements for Detection...

Previous example: K^+ →

Analyte
Concentration
(copies/ml)
to
Sample Volume (L)

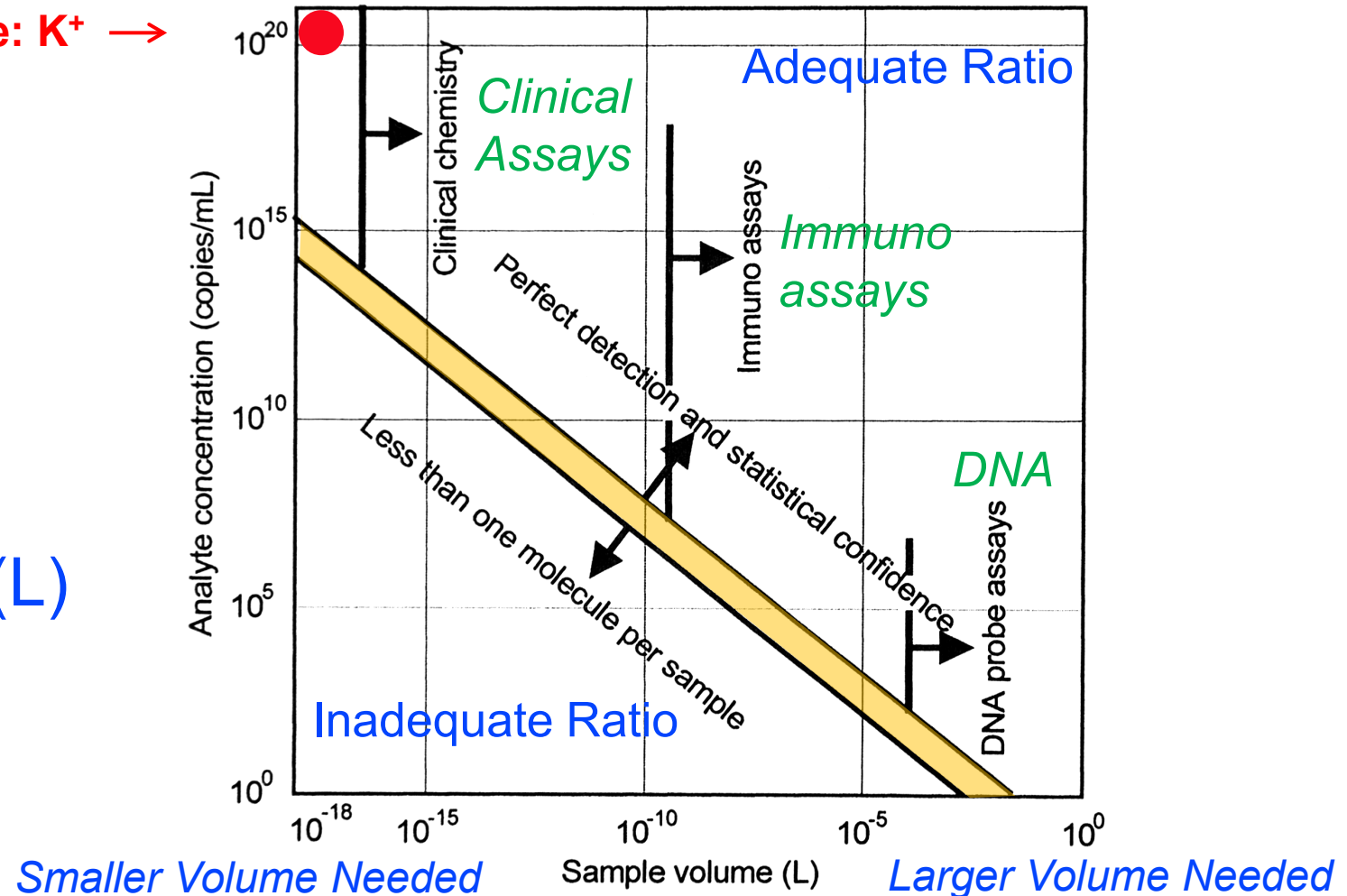

What is a Fluid?

- *A fluid is a substance that deforms continuously under the application of shear (tangential) stress of any magnitude.*
- Newtonian fluid – shear force is directly proportional to the rate of strain (shown between a fixed and moving plate).
 - This includes most fluids and gasses.

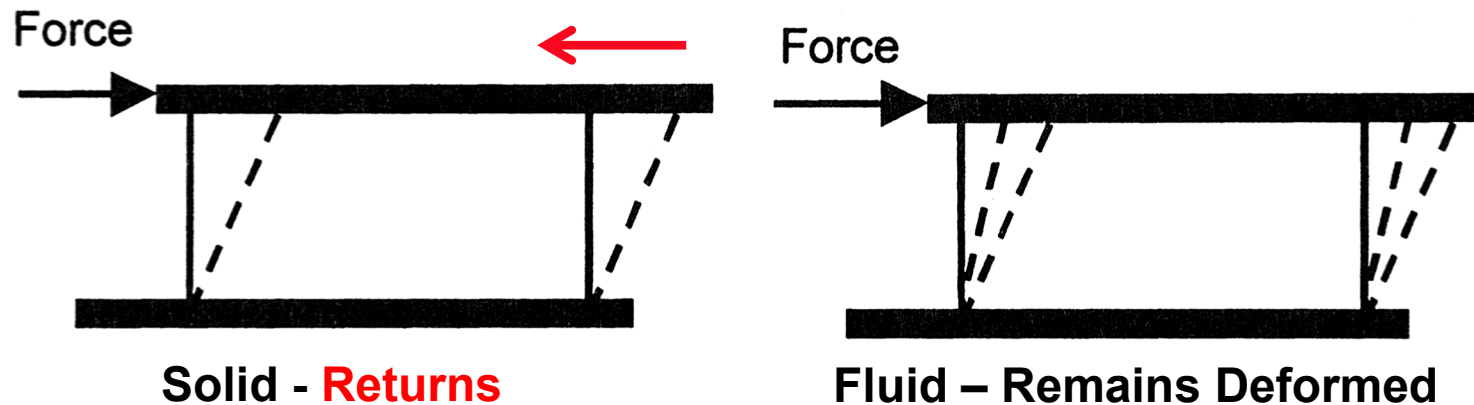

Concepts in Fluid Mechanics

- Continuum assumption
 - Fluid characteristics vary continuously throughout the fluid.
 - May not be true with certain molecular content.
- Laminar vs. transitional and turbulent flow.
 - Based on Reynolds number.
- Hagen-Poiseuille flow (*pwäz-ā-ă*)
- Poiseuille's law.
- Fluid kinematics (appendix)

Factors Influencing Flow...

- **Kinematic properties** - velocity, viscosity, acceleration, vorticity.
- **Transport properties** - viscosity, thermal conductivity, diffusivity.
- **Thermodynamic properties** - pressure, thermal conductivity, density.
- **Other properties** - surface tension, vapor pressure, surface accommodation coefficients.

Viscosity



Some Definitions: *Viscosity*...

- *Viscosity*

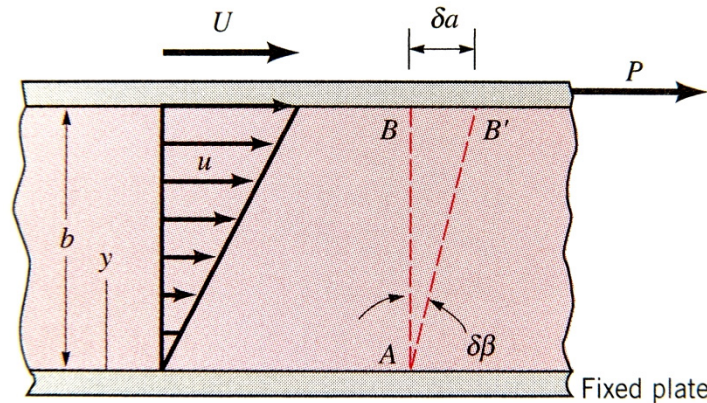

$$\tau = \mu \frac{du}{dy},$$

where

τ (tau) is the shearing stress,

μ (mu) is the absolute or dynamic viscosity, and

$\frac{du}{dy}$ is the velocity gradient.

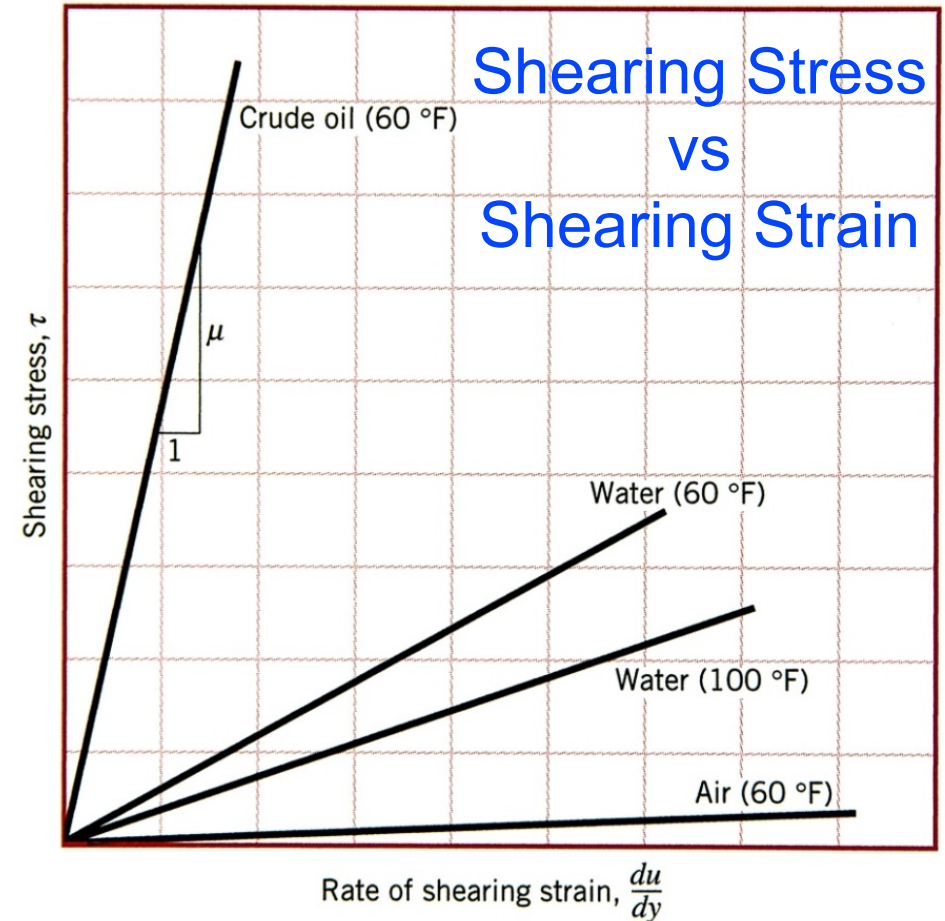

Kinematic Viscosity...

- *Kinematic viscosity* of a fluid relates the absolute viscosity to density:

$$\nu = \frac{\mu}{\rho},$$

where

ν (nu) is the kinematic velocity (m^2/s),

μ (mu) is the absolute viscosity, and

ρ (rho) is the density or mass per unit volume;

Specific Weight & Specific Gravity...

- The *specific weight* of a fluid is defined as the weight per unit volume:

$$\gamma = \rho g,$$

where

γ (gamma) is specific weight,

ρ (rho) is the density or mass per unit volume,

g is the local acceleration due to gravity;

- The *specific gravity* (SG) of a fluid is the ratio of the density of the fluid to the density of water at some specified temperature:

$$SG = \frac{\rho}{\rho_{H_2O@4^\circ C}}$$

Reynolds Number

- In circular tube flows without obstruction, conventional fluid mechanics would dictate that **Reynolds numbers** smaller than about **2100** typically indicate *laminar flow*, while values greater than **4000** are *turbulent*. In between is *transitional*.
- Ratio between inertial and viscous forces:

$$Re = \frac{\rho V D}{\mu}$$

where

ρ (rho) is the fluid density,

V is the mean fluid velocity (or u)

D is the pipe diameter (or L , the characteristic length)

μ (mu) is the fluid viscosity.



Osborne Reynolds lived from 1842 to 1912 and was an Irish fluid dynamics engineer.

Laminar vs Turbulent Flow...

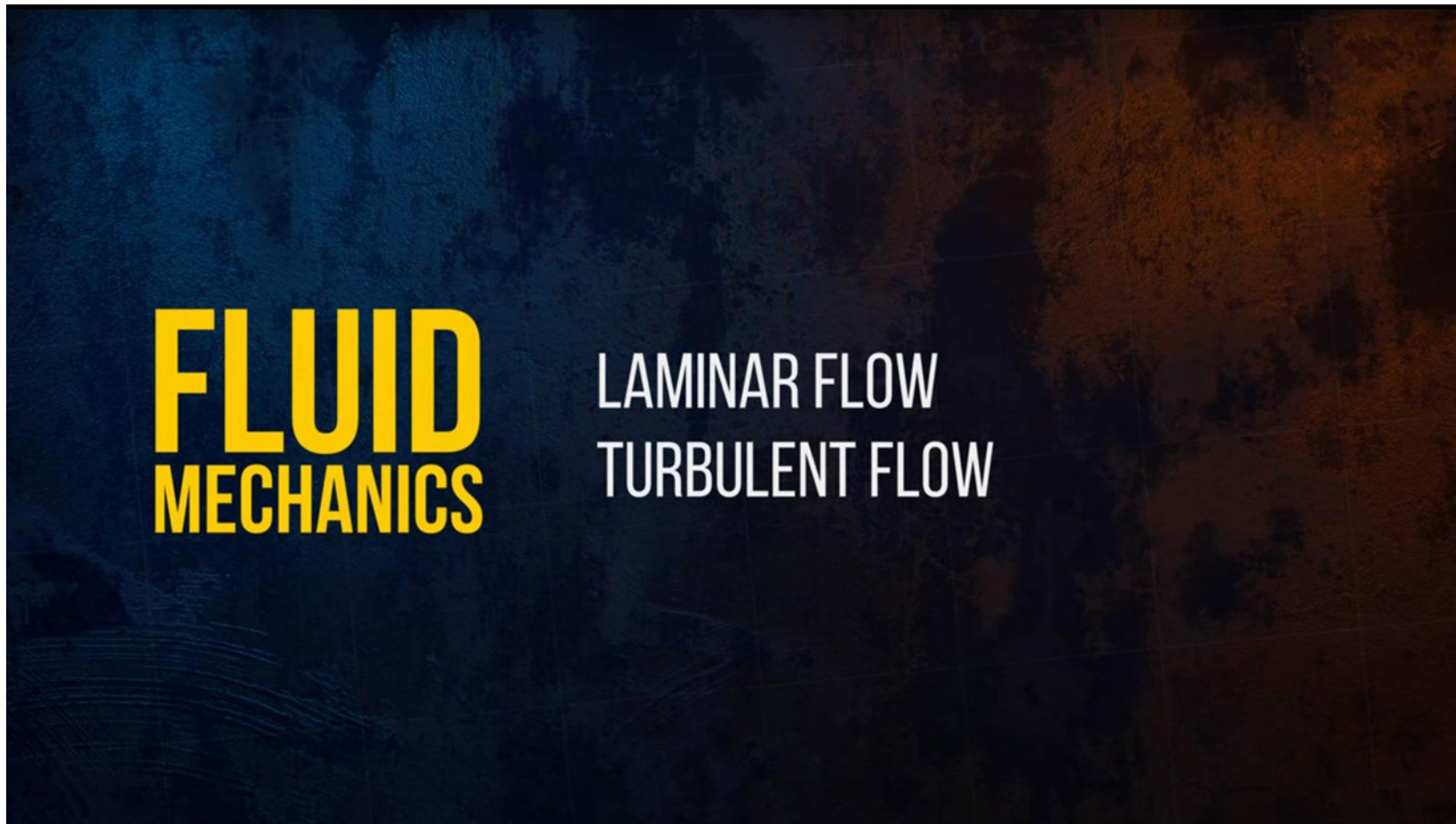

Example: Reynolds Number

- In a channel carrying water (viscosity of 10^{-3} kg/(s m), density of 10^3 kg/m³), in a channel with diameter of 10 μ m, at a velocity of 1 mm/s, the Reynolds number is 10^{-2} :

$$Re = \frac{10^3 \frac{kg}{m^3} \times 10^{-3} \frac{m}{s} \times 10^{-5} m}{10^{-3} \frac{kg}{s m}} = .01$$

- Contrast this to a channel with diameter of 100 μm and fluid velocity of 10 m/s, where the Reynolds number is a 1000:

$$Re = \frac{10^3 \frac{kg}{m^3} \times 10 \frac{m}{s} \times 10^{-4} m}{10^{-3} \frac{kg}{s \cdot m}} = 1000$$

- With channels < 1 mm in width and height, and velocities not greater than cm/s range, the Reynolds number for flow will be so low that all flow will be **laminar**.
 - In laminar flow, velocity of a particle is not a random function of time.
 - Useful for assays and sorting by particle size, and allows for creation of discrete packets of fluid that can be moved around in a controlled manner.

Microfluidic Flow Challenges

- Flows at low *Reynolds numbers* pose a challenge for mixing. Two or more streams flowing in contact with each other will mix only by *diffusion*.
- As *surface area to volume* increases, *surface tension* forces become significant, leading to nonlinear free-boundary problems.
- As suspended *particle sizes* approach the size of the channel, there is a breakdown of the traditional constitutive equations.

Hagen-Poiseuille Flow *(French - pwäz-ā-ă)*

- *Hagen-Poiseuille flow* or *Poiseuille flow* is the steady, incompressible, laminar flow through a circular tube of constant cross section. The velocity distribution is expressed as :

$$v_z = \frac{1}{4\mu} \left(\frac{\partial p}{\partial z} \right) (r^2 - R^2),$$

where

v_z is the longitudinal velocity,

μ (mu) is the fluid viscosity,

$\partial p / \partial z$ is the z component of the pressure gradient,

r is the distance from the center of the tube, and

R is the radius of the tube.

Velocity Distribution ...

- The **velocity distribution** is **parabolic** at any cross sectional view:

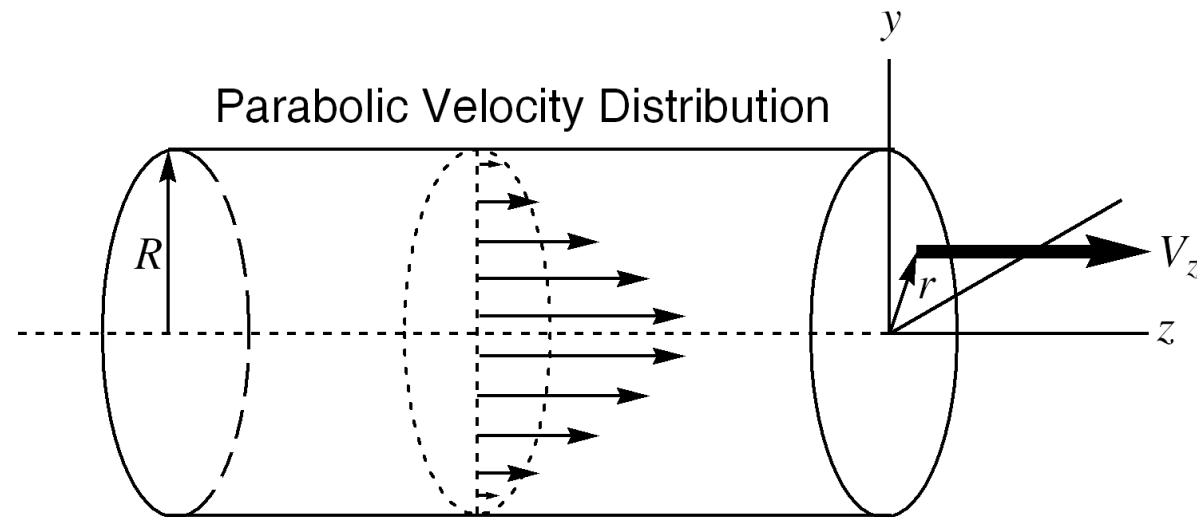

- Each part of the fluid can be visualized as moving along its own path line.
- The *maximum velocity* is at the pipe center.
- The *minimum velocity* (zero) is at the pipe wall.
- Shear stress is the consequence of the velocity variation and fluid viscosity.

Poiseuille's Law (pwäz-ā-ǎ) ...

- *Poiseuille's law* describes the relationship between the *volume rate of flow*, Q , passing through the tube and the *pressure gradient* (from the Navier-Stokes equations):

$$Q = \frac{\pi D^4 \Delta p}{128 \mu \ell} = \frac{\pi R^4 \Delta p}{8 \mu \ell},$$

where

Q is the volume rate of flow,

D is the diameter of the tube,

Δp is pressure drop over length, ℓ along the tube,

μ (mu) is the fluid viscosity, and

R is the radius of the tube.

- For a given pressure drop per unit length, the volume flow rate is inversely proportional to the viscosity and proportional to the tube radius to the fourth power.
- Doubling of the tube radius produces a 16-fold increase in flow.
 - Conversely, decreasing the radius by half (such as in an atherosclerotic coronary artery), decreases flow by 16-fold.

- The *mean velocity* is:

$$V = \frac{Q}{\pi R^2} = \frac{R^2 \Delta p}{8\mu \ell}$$

and the *maximum velocity* occurring at the center of the tube is:

$$v_{\max}$$

Surface Area to Volume

- Surface area to volume (SAV) increases significantly as dimensions are reduced for microfluidic channels.
 - For example, for a circular microchannel 100 μm in diameter, the SAV ratio is:

$$SAV = \frac{2\pi rL}{\pi r^2 L} = \frac{2}{r} = 4 \times 10^4 \text{m}^{-1},$$

where

r is the radius, and
 L is the length.

Diffusion

- In **laminar flow**, two or more streams flowing in contact with each other mix only by *diffusion*.

$$\bar{x}^2 = 2Dt,$$

where

x is the distance a particle moves,
 t is the amount of time, and
 D is the diffusion coefficient.

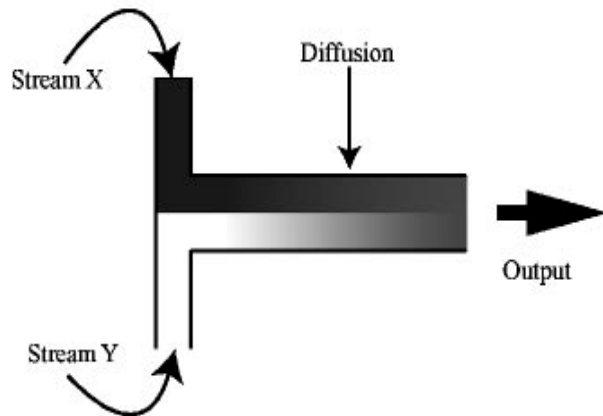

$$D = \frac{RT}{6\pi r\eta N_A} \left[1 + C \left(\frac{\partial \ln y}{\partial C} \right)_{T,P} \right],$$

where

R is the gas constant, T is temperature,
 r is particle radius,
 N_A is Avogadro's number,
 C is concentration in moles/liter,
 η (eta) is the solution viscosity, and
 y is the activity coefficient in moles/liter.

Example: Diffusion of Hemoglobin

- How long does it take **hemoglobin** to diffuse 1 cm in water ($D=10^{-7}\text{cm}^2\text{s}^{-1}$)?

$$t_s = \frac{(1\text{cm})^2}{2 \times \frac{\text{cm}^2}{10^7\text{s}}} = 5 \times 10^6 \text{ s} \quad \text{(58 days!)}$$

- How long to diffuse 10 μm (.001 cm)?

$$t_s = \frac{(10^{-3}\text{cm})^2}{2 \times \frac{\text{cm}^2}{10^7\text{s}}} = 5 \text{ s}$$

Design Considerations...

- The optimal size domain for microfluidic channel cross sections is somewhere between 10 -100 μm .
- At smaller dimensions detection is too difficult and at greater dimensions unaided mixing is too slow.
- Therefore, the cross sectional area for a square channel with width of 50 μm will be $\sim 2.5 \times 10^{-3} \text{ mm}^2$. The flow range will be 1 to 20 nL/sec.
- *When diluting an assay component, the two flows must be controlled within $\sim 1\%$, or pL/sec range.*

Summary

- Length & volume in the micro realm.
- Clinically relevant analyte concentrations.
- Sample volume determination.
- Fluid mechanics:
 - Reynolds number - laminar and turbulent flow.
 - Hagen-Poiseuille flow or Poiseuille flow (*pwäz-ā-ă*)
 - Poiseuille's law.
- Surface area to volume
- Diffusion
- Addendum – COMSOL & Fluid Kinematics

Addendum

- COMSOL in Bioengineering:
https://youtu.be/TyLcN_N60gw.
- Modeling diffusion in a model biosensor using COMSOL Multiphysics:
 - Part 1: https://youtu.be/s8cfMxd_FYE.
 - Part 2: <https://youtu.be/GT8LWS71d1A>.
 - Part 3: <https://youtu.be/ZrEO5E8JK2g>.
- COMSOL demo of laminar flow through branch pipes:
<https://youtu.be/ZZbe5DBvRf0>.
- More on fluid kinematics.

Fluid Kinematics

- A **field representation** of flow is the representation of fluid parameters as functions of **spacial coordinates** and **time**.
- The **velocity field** is defined as:

$$\mathbf{V} = u(x, y, z, t)\hat{\mathbf{i}} + v(x, y, z, t)\hat{\mathbf{j}} + w(x, y, z, t)\hat{\mathbf{k}},$$

where

u, v, w are the $x, y,$ and z components of the velocity vector, and t is time.

- For problems related to flow in most microchannels, we can consider that one or two of the velocity components will be small relative to the others, and reduce the problem to 1D or 2D flow.

Position Vector...

- Particle *location* is in terms of its position vector \mathbf{r}_A :

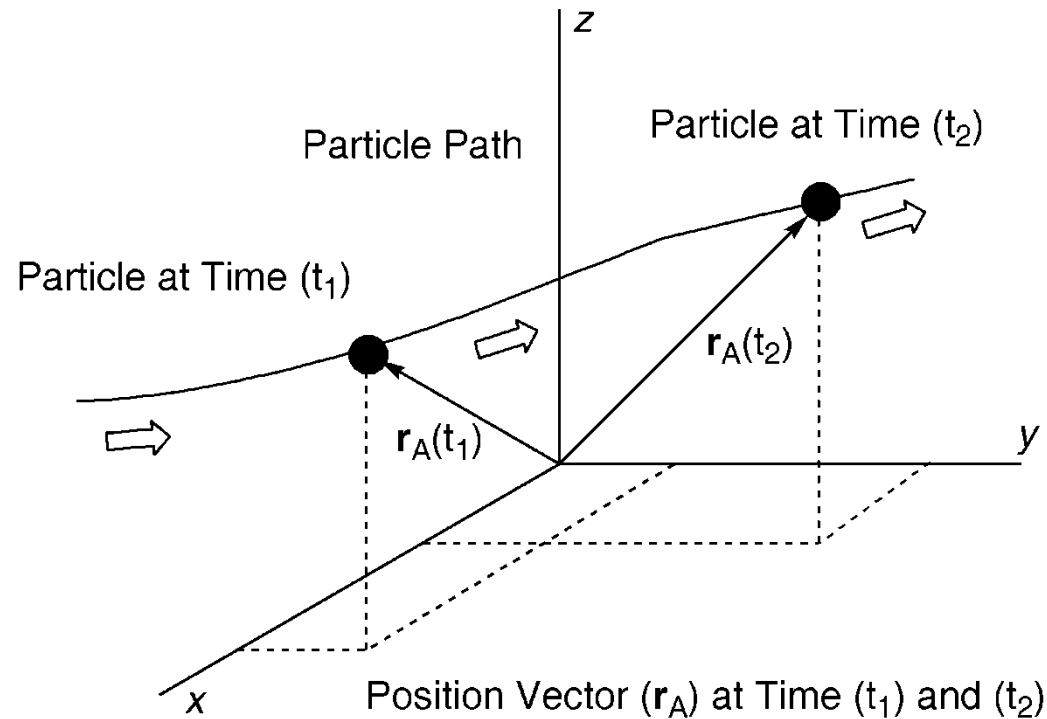

The velocity of a particle is the time rate of change of the position vector for that particle.

- The *velocity* of a particle is the time rate of change of the position vector r_A for that particle:

$$d\mathbf{r}_A/dt = \mathbf{V}_A$$

- The *direction* of the fluid velocity relative to the x axis is given by:

$$\tan \theta = \frac{v}{u}$$

“Streamlines”...

- A *streamline* is a line that is everywhere tangent to the velocity field. In **steady flows**, the streamline is the same as the *path line*, the line traced out by a given particle as it flows from one point to another.

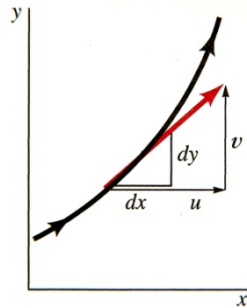

$$\tan \theta = \frac{v}{u}$$

- For a 2D flow the slope of the streamline must be equal to the tangent of the angle that the velocity vector makes with the x axis:

$$\frac{dy}{dx} = \frac{v}{u}$$

- If the velocity field is known as a function of x and y , this equation can be integrated to give the equation of the streamlines.
- The notation for a streamline is:

$$\psi \text{ (psi)} = \text{constant on a streamline}$$

- The *stream function* is:

$$\psi = \psi(x, y)$$

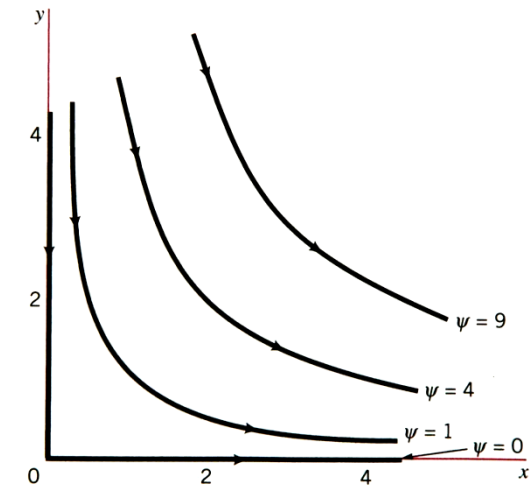

- Various lines can be plotted in the x - y plane for different values of the constant. For steady flow, the resulting streamlines are lines parallel to the velocity field.

Uniform Flow...

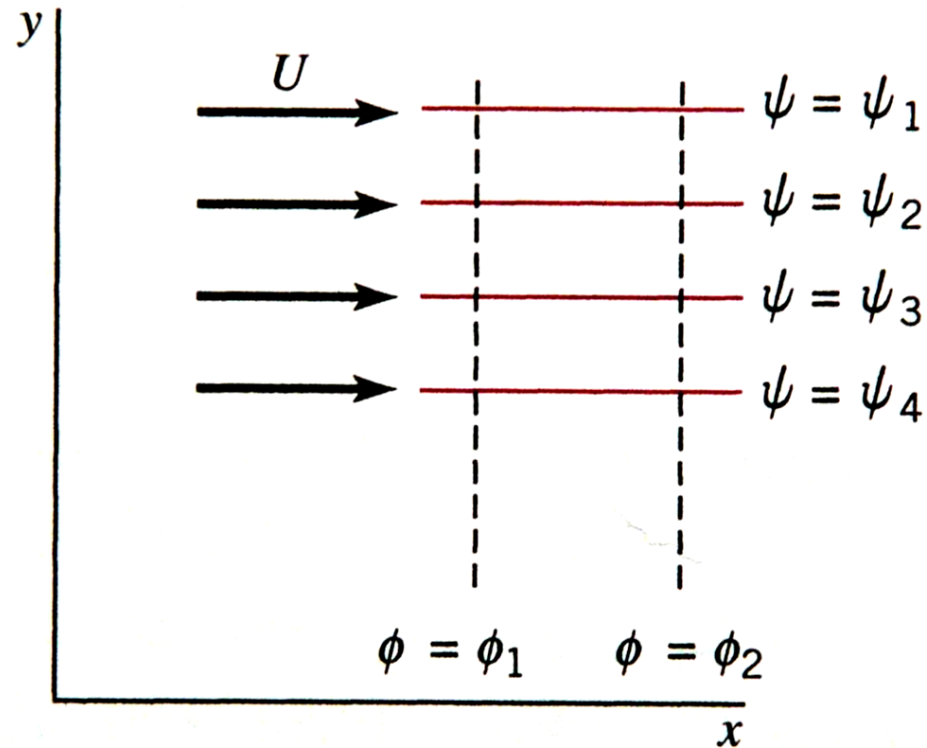

The streamlines are all straight and parallel, and the magnitude of the velocity is constant.

Streamline Coordinates...

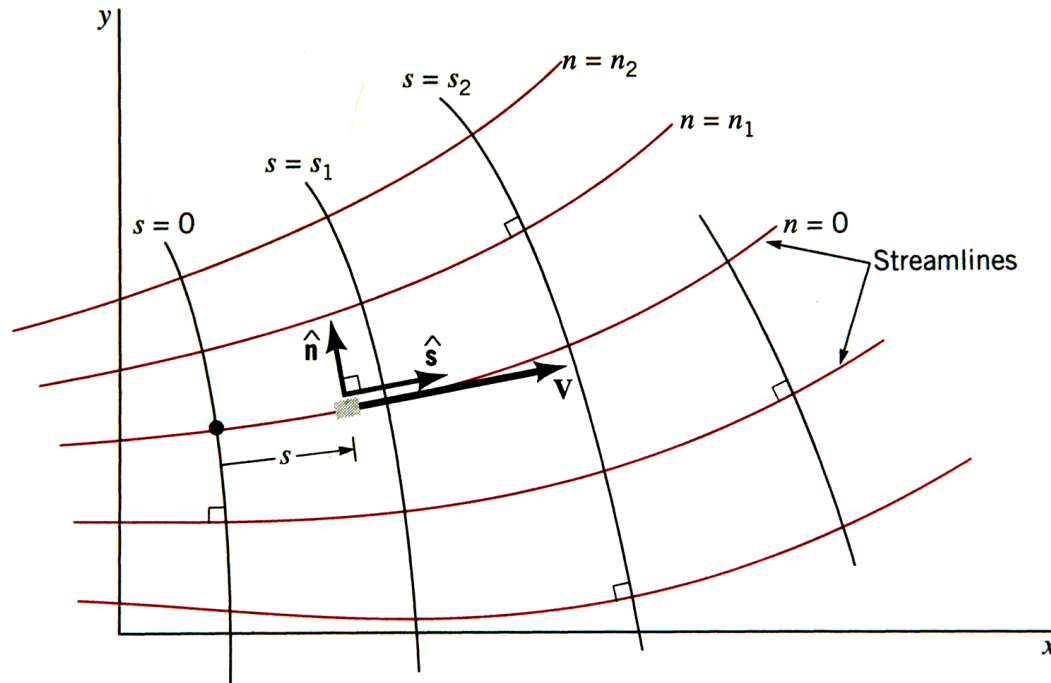

$\mathbf{V} = V\hat{\mathbf{s}}$
Velocity is always tangent to the s direction.

- Example of a steady 2D flow.
- “ s ” is a unit vector along the streamline.
- “ n ” is normal to the streamline.
- Velocity is always tangent to the “ s ” direction.

Flow Around a Circular Cylinder...

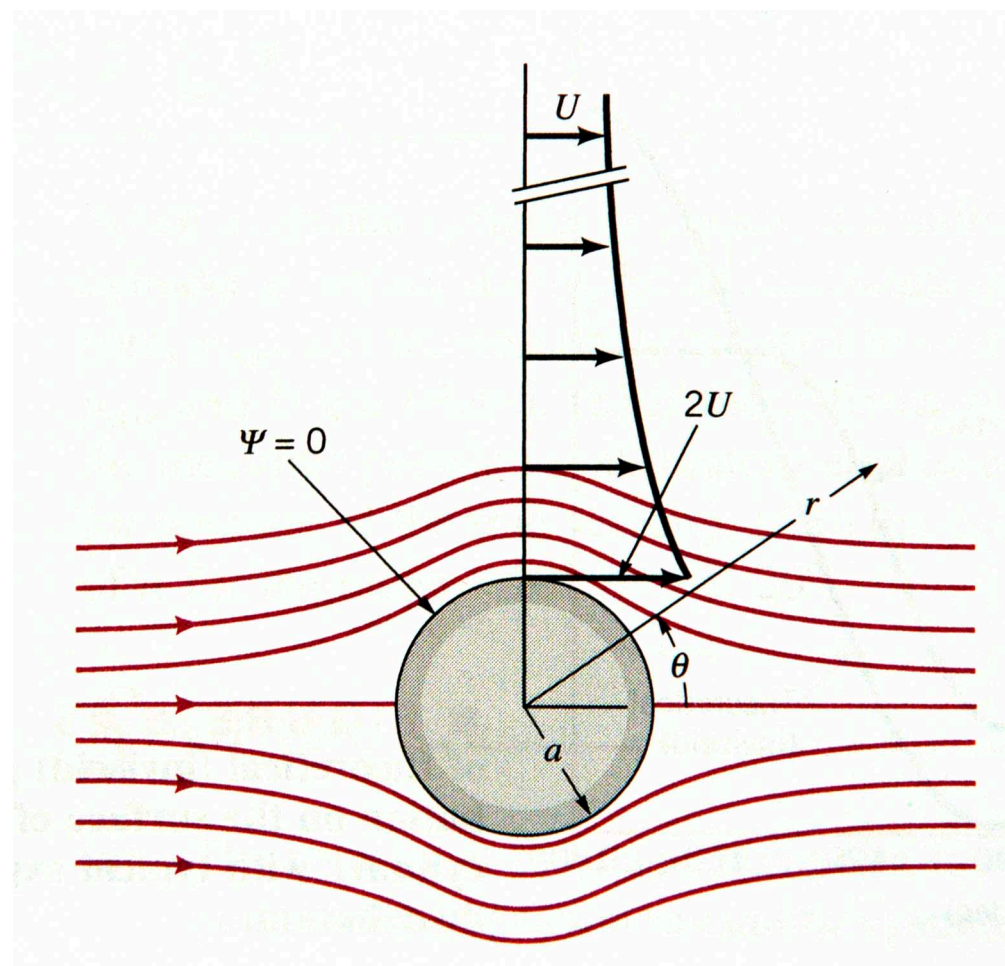

“Flow Net” and the Velocity Potential Phi...

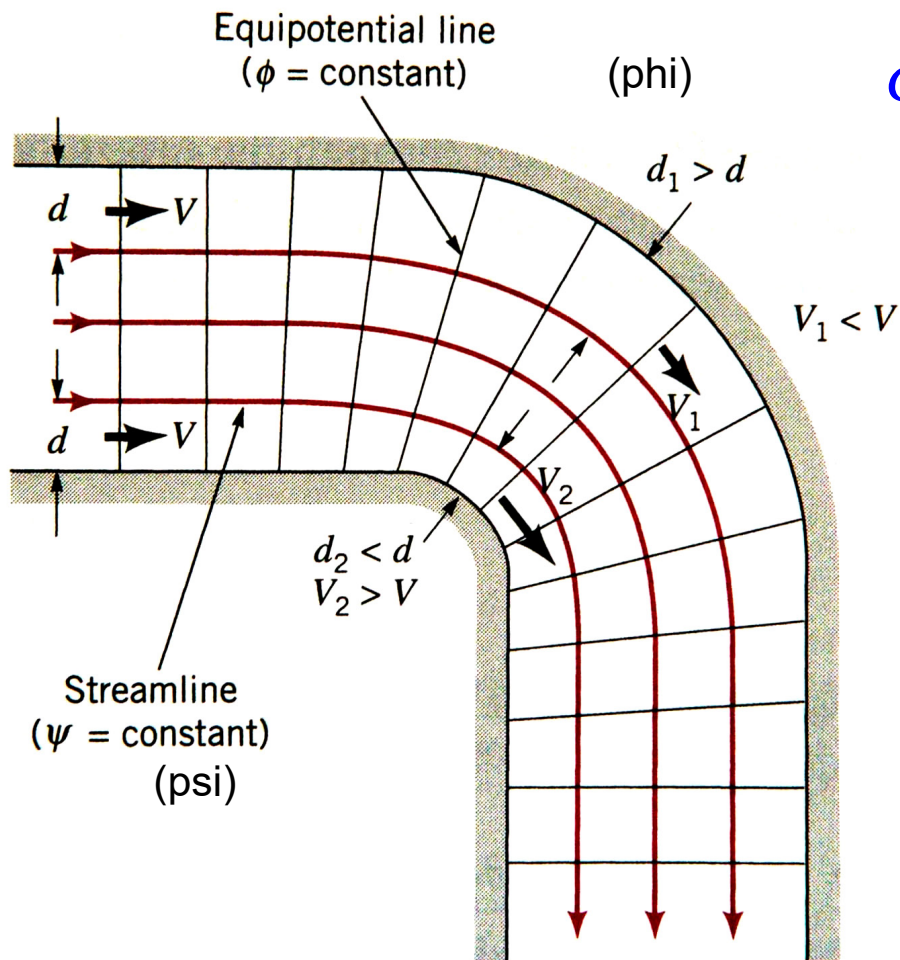

$$\phi(x, y, z, t) \quad u = \frac{\partial \phi}{\partial x} \quad v = \frac{\partial \phi}{\partial y} \quad w = \frac{\partial \phi}{\partial z}$$

- A flow net consists of a family of streamlines and equipotential lines.
- Velocities can be estimated from the flow net, as the velocity is inversely proportional to the streamline spacing.
- At the 90° bend, velocity is higher near the inside corner.