

# Actuators & Motors

Prof. Steven S. Saliterman

Introductory Medical Device Prototyping

Department of Biomedical Engineering, University of Minnesota

<http://saliterman.umn.edu/>



# Topics

- ▶ Definition of an actuator.
- ▶ Control signals
- ▶ Relays – electromechanical.
  - Bipolar Junction Transistors
- ▶ Solid State Power Switching
  - Silicon Controlled Rectifiers
  - Triac
- ▶ DC motors, RC servos and stepper motors:
  - Unijunction transistor
  - Field effect transistors
- ▶ Stepper motors and linear actuators.
- ▶ Fluid pumps and flow sensors
- ▶ Pneumatic systems.

# What is an actuator?

- ▶ *A device that responds to a control signal and accomplishes something useful!*
  - An injector mechanism of an insulin pump in response to a patient's manual command or feedback loop with an integrated glucose sensor.
  - A relay driven by the a low current output pin of a microcontroller, switching on a high power circuit.
  - An alarm that sounds then vital signs are critical.
  - A microvalve made of pH sensitive hydrogel, opening and closing a fluid conduit in a lab-on-chip device.
  - A piezoelectric, magnetic or electrostatic micropump.

- ▶ *Industrial actuators* are typically performing motion – derived by pneumatic, electrical, or hydraulic systems– and are useful for many prototyping projects.
  - e.g. relays, valves, pumps, motors, stepping motors, linear actuators, servos and pneumatic cylinders.
- ▶ With *microfabrication* we can incorporate a variety of energies and materials:
  - Piezoelectric effects, electrostatic forces, magnetic forces, thermal transformation, shape memory alloys, hydrogels, electroactive polymers (ionic and non–ionic), and dielectric electroactive polymers.
  - These topic are covered in *BME 5151 Intro to BioMEMS and Medical Microdevices*.

# *Actuator for Diabetes Mellitus...*

- ▶ MiniMed Paradigm Revel™ Insulin Pump has built-in continuous glucose monitoring (CGM), and offers round-the-clock glucose monitoring.
- ▶ This pump also delivers early notification of oncoming lows and highs so that the patient can react quickly to changes in sugar level.



# *Actuator for Pain Control...*

- ▶ The Medtronic SynchroMed II® programmable infusion system for intrathecal drug delivery includes an implanted pump that can be noninvasively programmed.
- ▶ Once implanted, the SynchroMed pump stores and delivers medication according to instructions programmed by the physician.



# Control Signal

- ▶ Typically there is a low energy *control signal* to a device (mechanism) that responds by performing some sort of work.
- ▶ The *control signal* may be the push of a finger, an electrical voltage or current, a pneumatic or hydraulic pressure, or even an environmental stimulus (temperature, gas, magnetic field, presence of an ion, pH etc.)
- ▶ Some *action* takes place – movement, pumping, switching, signalling etc.
- ▶ There will be a *transduction of energy*, and energy will be expended in the process.

# Relays

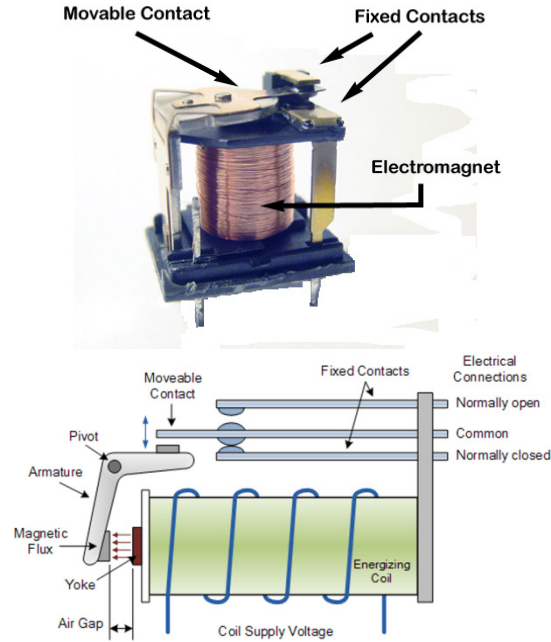

Electromechanical relay.

- ▶ Essentially a switch.
- ▶ When voltage is applied to the coil, the moveable contact comes down by magnetic attraction, switching the circuit between the upper to lower fixed contact.
- ▶ A 12 VDC coil for example, may require 200 mA, while the contacts can handle a load of much higher voltage and current dependent on the *contact ratings*.
- ▶ Many relays today are “solid state”, based on *silicon controlled rectifiers*.



# Bipolar Junction Transistors (BJT)...

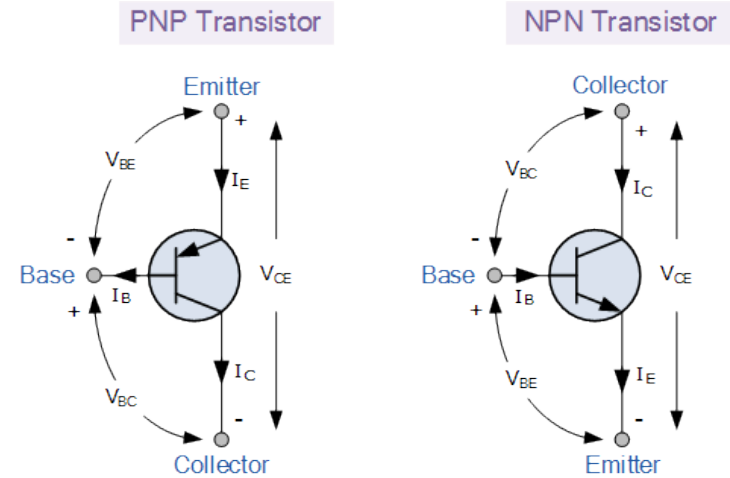
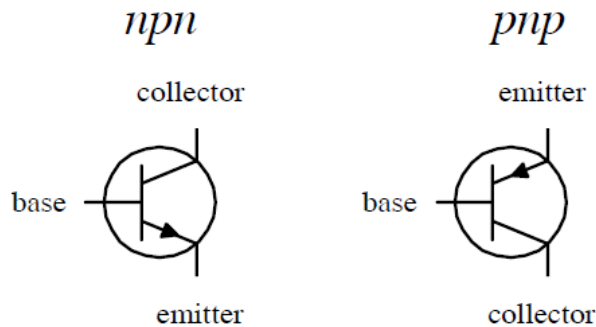

- ▶ We previously discussed BJT transistors in relationship to amplifiers and switching.
- ▶ BJTs are “current operated devices” where a much smaller Base current causes a larger Emitter to Collector current.

# *BJTs...*

- ▶ They requires a Biasing voltage for AC amplifier operation.
- ▶  $I_E = I_B + I_C$
- ▶ A transistor can also be used as an electronic switch between its saturation and cut-off regions to control devices such as lamps, motors and solenoids etc.
- ▶ Inductive loads such as DC motors, relays and solenoids require a reverse biased “Flywheel” diode placed across the load. This helps prevent any induced back EMF generated when the load is switched “OFF” from damaging the transistor.

# BJT Characteristic Curve...

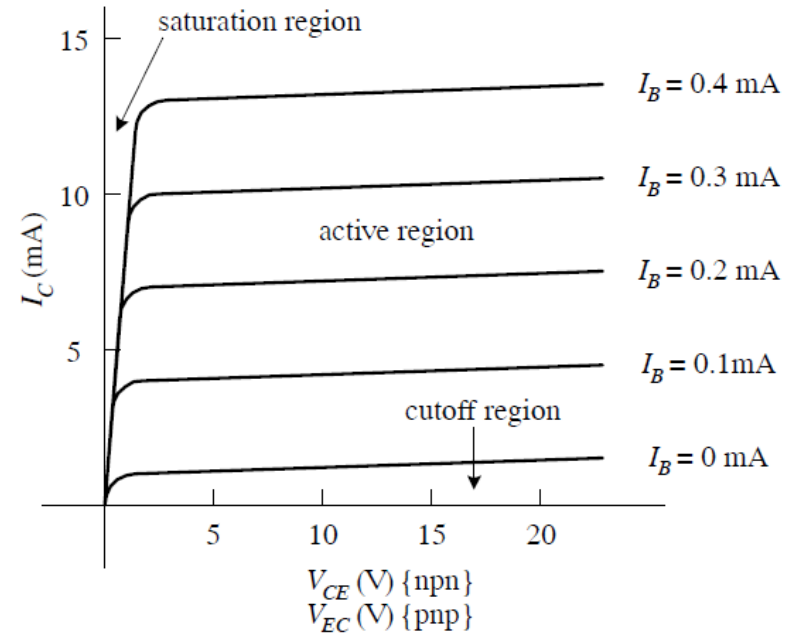
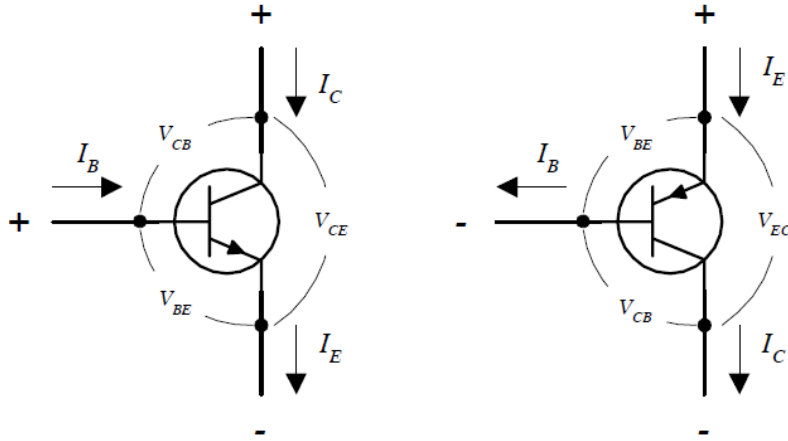

- ▶ Effects the base current  $I_B$  and the emitter-to-collector voltage  $V_{EC}$  have on the emitter/collector currents  $I_E$  and  $I_C$ .

# Relay Driver with Transient Suppression...

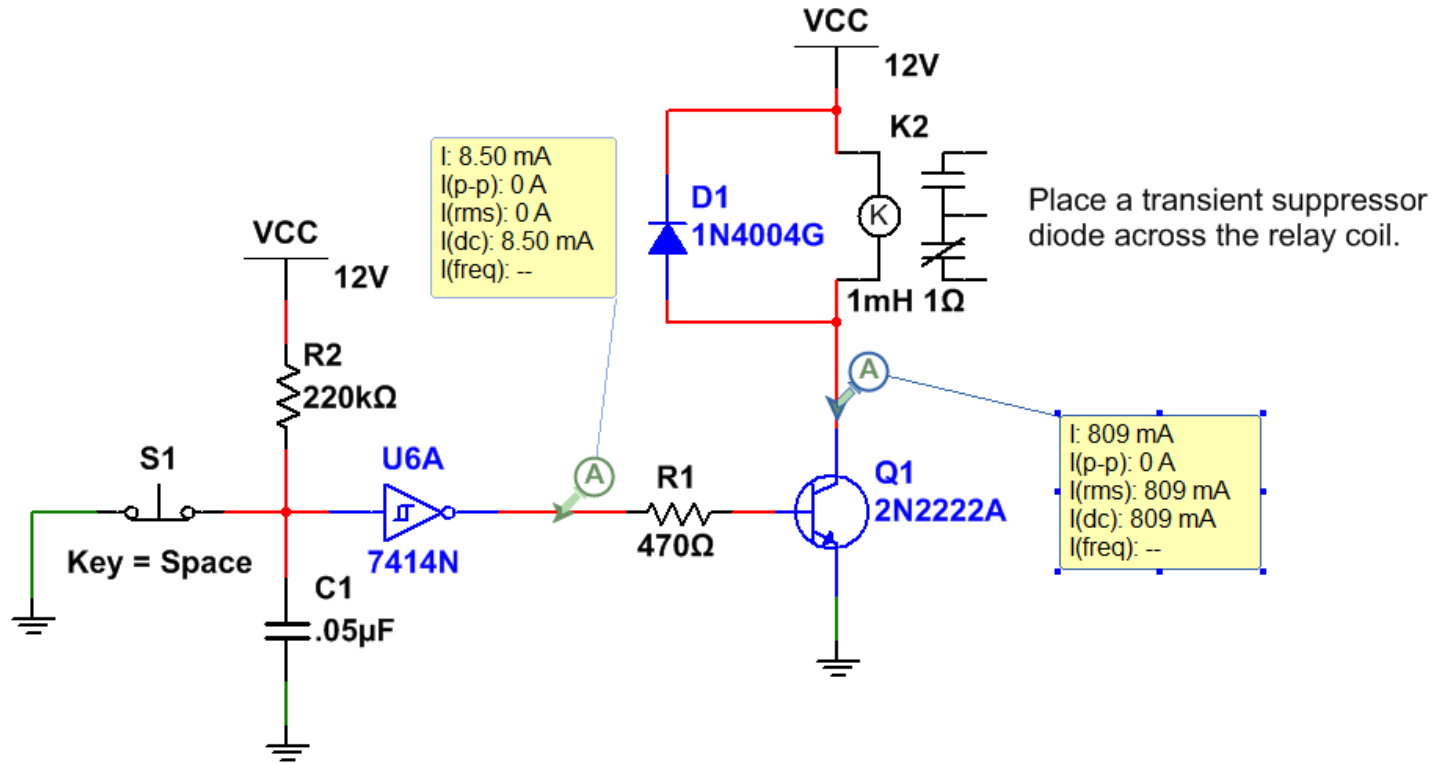

# *Examples of Relays...*



4PDT 12VDC 5A.  
14 Pin Terminals Relay and Socket.  
Contact Capacity to 5A.



2A DPDT PC Mount Relay



Two-Coil Latching – Set and Reset

# *Relay Modules and Arduino Shield...*



Image courtesy of Vetco Electronics

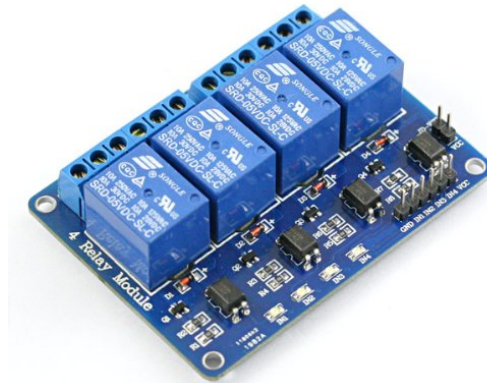

SainSmart 5V Relay Board

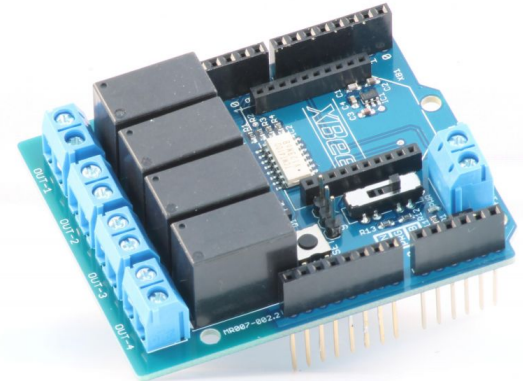

Relay Shield for Arduino  
Image courtesy of Microbot  
di Prosseda Mirko

# Examples of Solid State Relays...

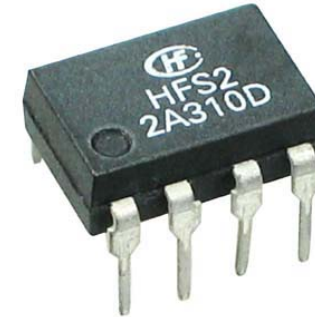
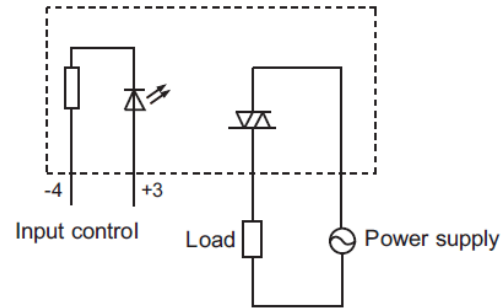

SPST 3-15VDC 5A Solid State Relay.  
SCR Chip, Photo Isolation.  
Output Switching Voltage: 48 – 280 VAC.  
Maximum Load Current: 0.1 – 5 A.  
Maximum Surge Current: 250 A.

Dual SPST DIP Solid State Relay.  
Input Control Current: 5-50 mA.  
Output Switching Voltage: 0 – 60 V AC/DC  
Load Current up to 400mA.

# *Silicon Controlled Rectifiers (Thyristor)...*

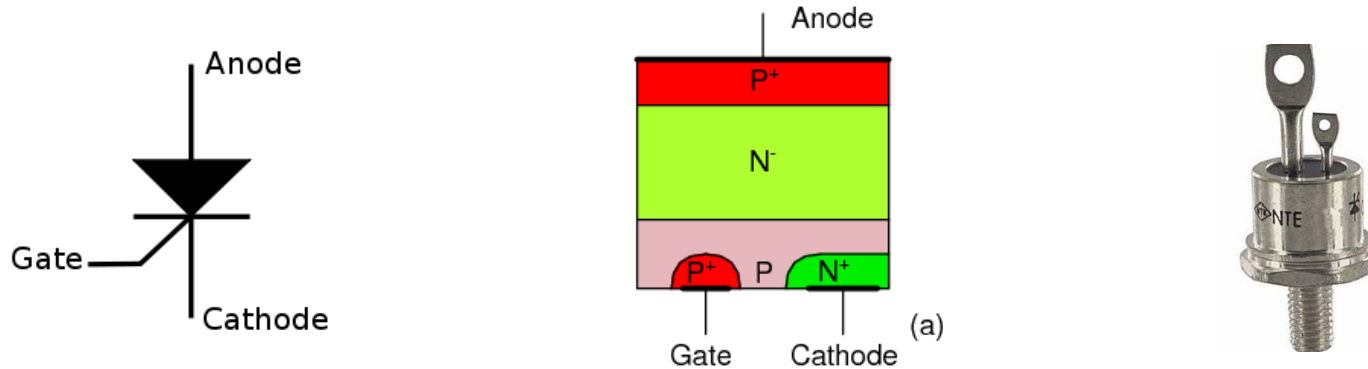

- ▶ The Silicon Controlled Rectifier (SCR) is simply a conventional rectifier controlled by a gate signal.



# Triac...

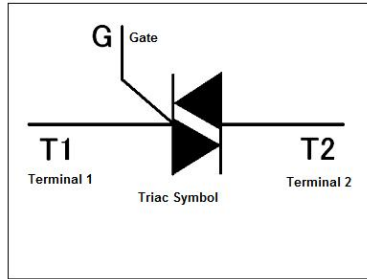

Image courtesy of  
Electronic Repair Guide.

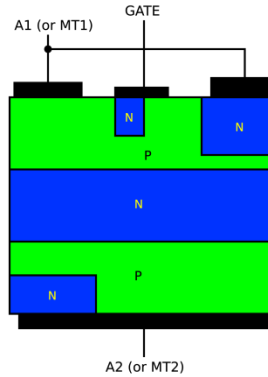
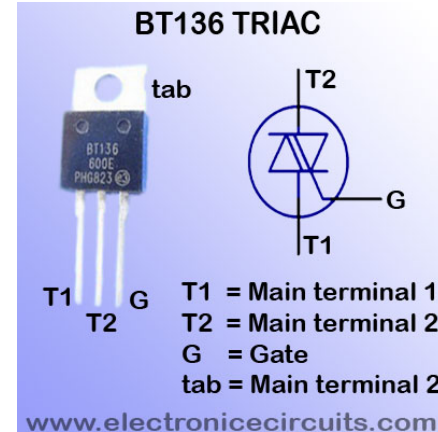
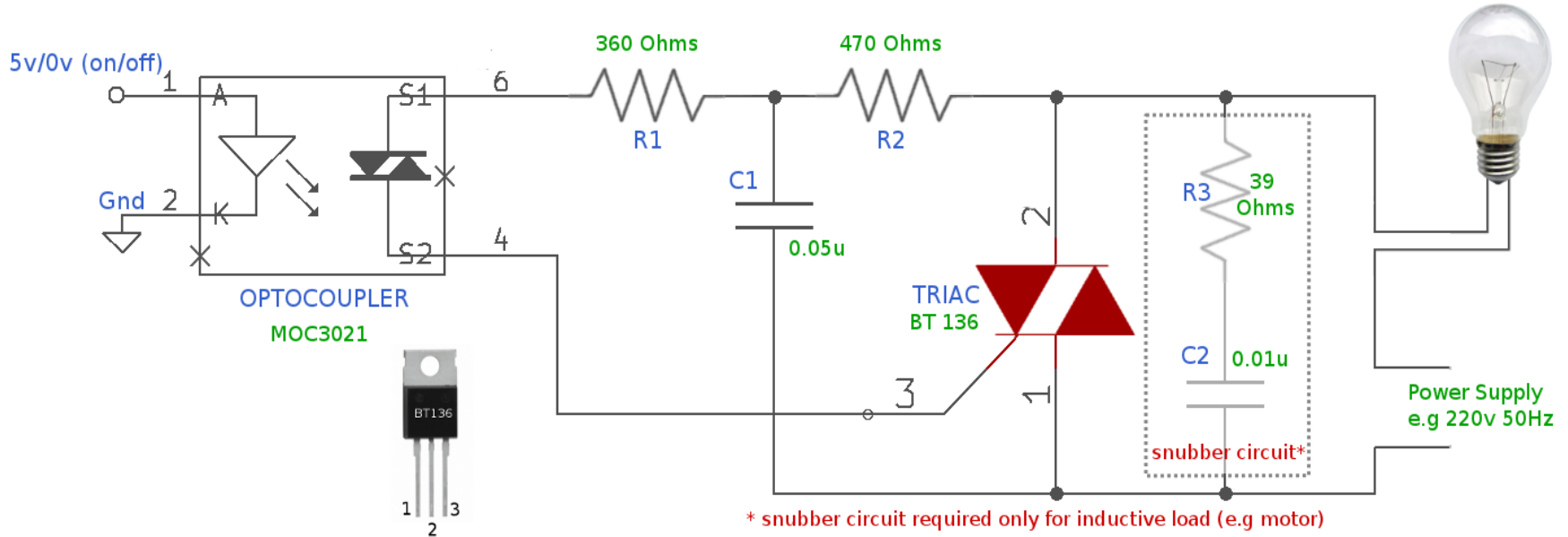

Image courtesy of  
Wikipedia



- ▶ Two anti-parallel SCRs. Generally used for motor speed control and in light dimmer.
- ▶ It can be triggered by either a positive or a negative voltage being applied to its gate electrode (with respect to T1, otherwise known as MT1 or A1).
  - Once triggered, the device continues to conduct until the current through it drops below a certain threshold value, the holding current, such as at the end of a half-cycle of alternating current (AC) mains power.

# Controlling a High Voltage Device...



# DC Motors

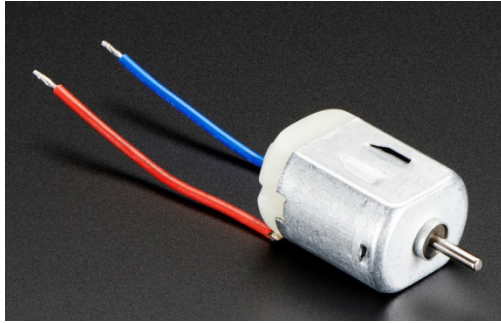

Image courtesy of Adafruit



Got Motion? LLC, DBA Loring & Associates

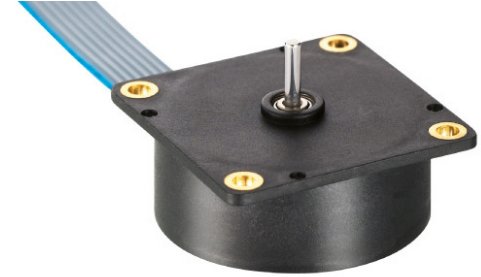
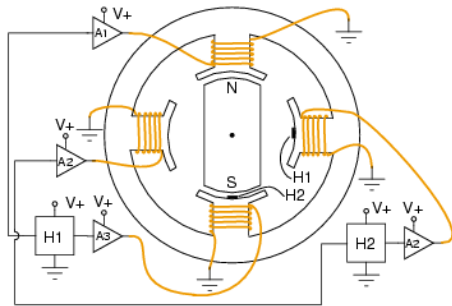
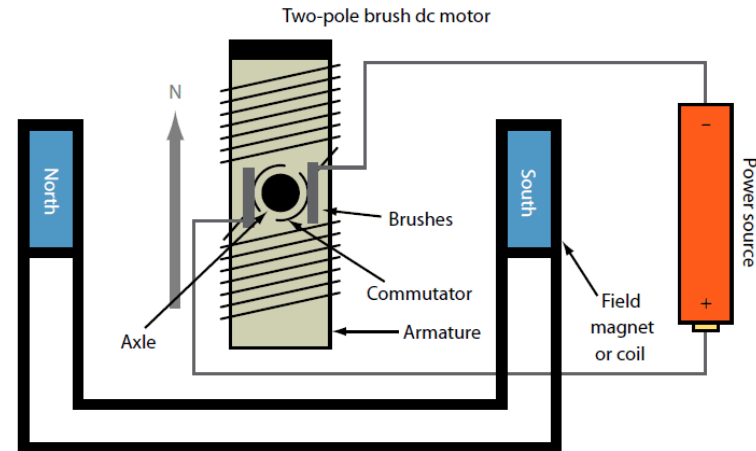

Image courtesy of Micromo



Brushless DC motor, ubooks.pub



Mat Dirjish, Electronic Design, February 16, 2012

# Unijunction Transistor (UJT)...

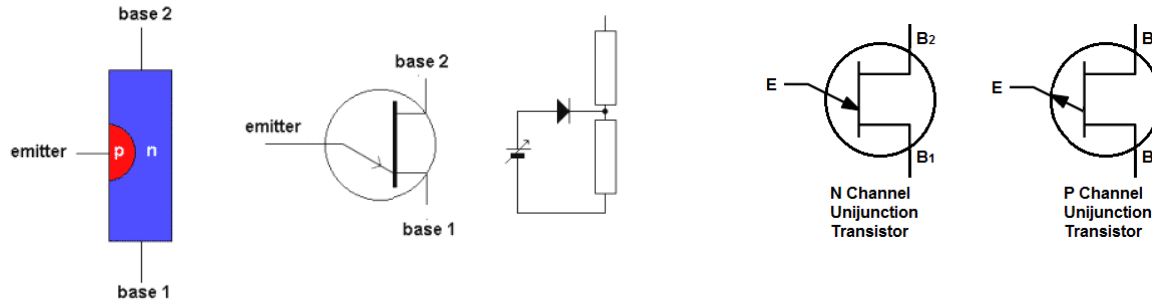

- ▶ Three-lead electronic semiconductor device with only one junction that acts exclusively as an electrically controlled switch. The UJT is not used as a linear amplifier.
- ▶ With the emitter unconnected, the bar acts as a potential divider, and about 0.5 volts appears at the emitter. If a voltage is connected to the emitter, as long as it is less than 0.5 volts, nothing happens, as the P-N junction is reversed biased. (see the right hand diagram).
- ▶ When the emitter voltage exceeds 0.5 volts, the junction is forward biased and emitter current will flow. This increase in current is equal to a reduction of resistance between base 1 and the emitter.
- ▶ Useful for triggering thyristors.

Left: Hobby Projects.com  
Middle: Learning about electronics.com  
Right: Image courtesy of Allied Electronics

# UJT/SCR Motor Control...

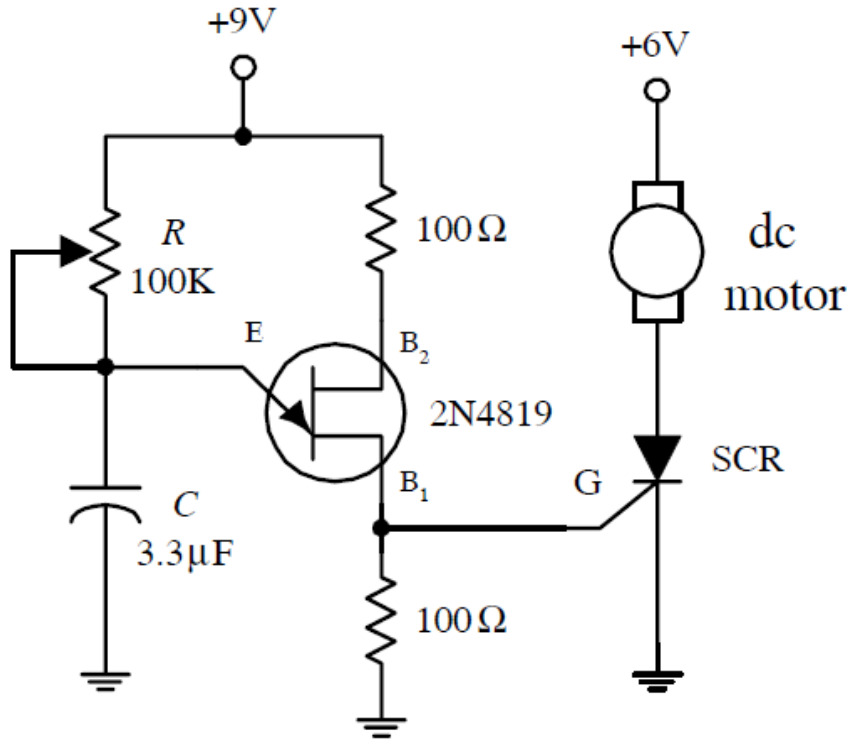

- ▶ Here we see control of motor speed by sending short pulses of current to the SCR.
- ▶ A UJT *relaxation oscillator* generates a series of pulses that drives an SCR on and off.
- ▶ To vary the speed of the motor, the UJT's oscillatory frequency is adjusted by changing the RC time constant.

# Field Effect Transistors (JFETS & MOSFETS)...

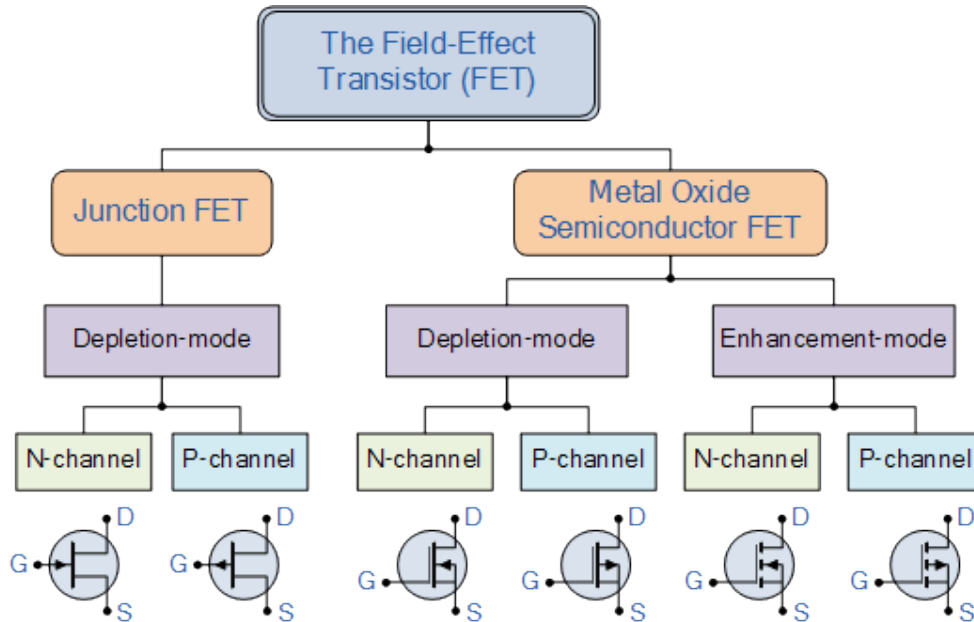

FET	vs	BJT
Low voltage gain.		High voltage gain.
High current gain.		Low current gain.
High input and out impedance.		Low input and output impedance.
Easily damaged by static		Robust
Voltage Controlled		Current Controlled
High current needs like motors & servos		Low current relays, LEDs, lamps, amps, & oscillators

# MOSFET Motor Control...

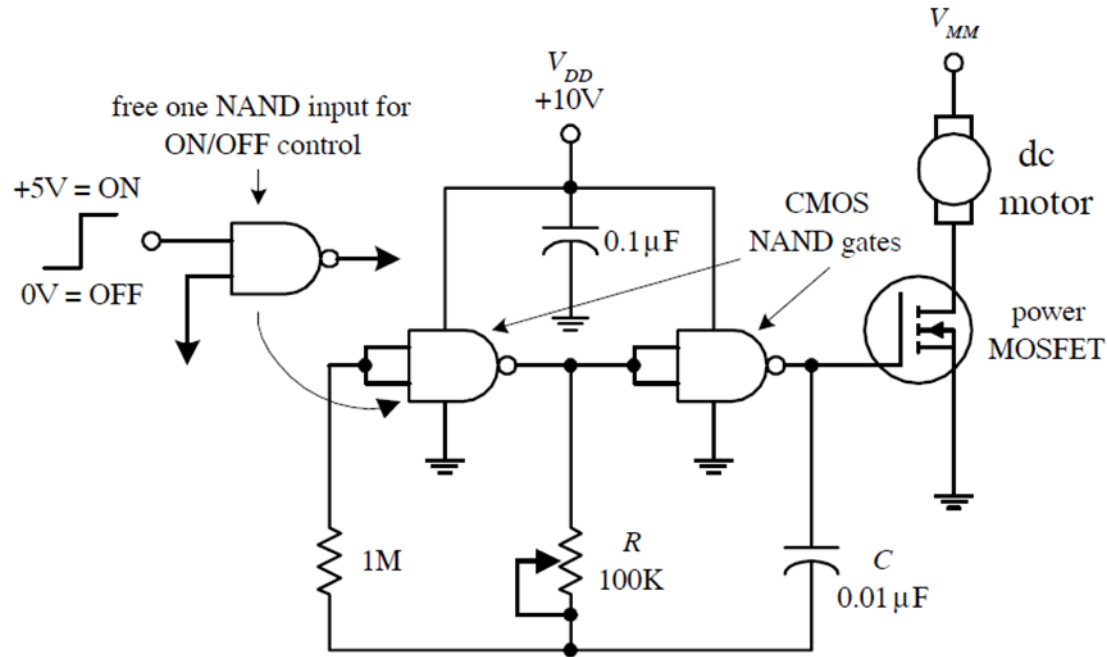

- ▶ The speed of the motor is controlled by the oscillator's RC time constant.
- ▶ Notice that if one of the input leads of the left NAND gate is pulled out, it is possible to create an extra terminal that can be used to provide on/off control that can be interfaced with CMOS logic circuits.

# LM555 Timer Motor Control...

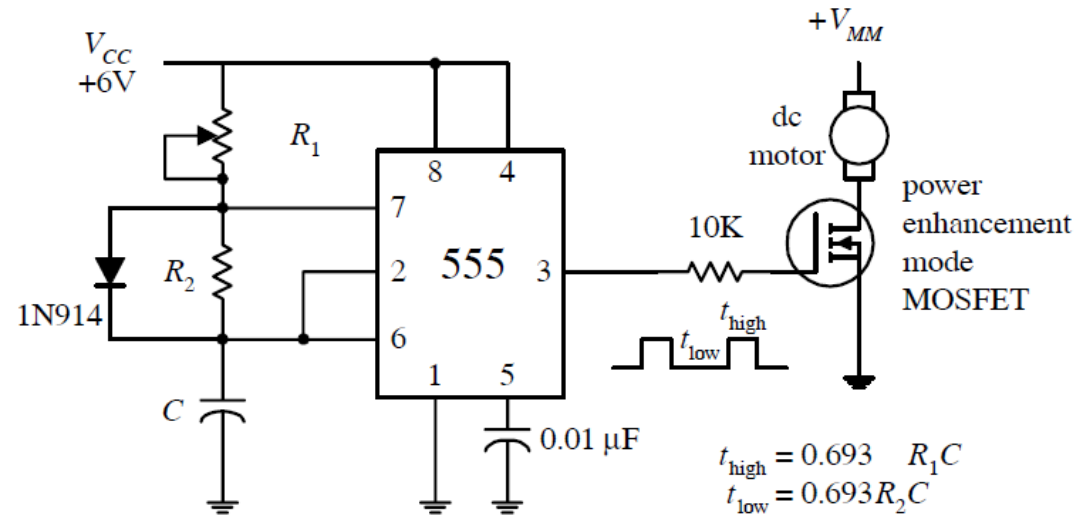

- ▶ By inserting a diode between pins 7 and 6, as shown, the 555 is placed into low-duty cycle operation.
- ▶  $R_1$ ,  $R_2$ , and  $C$  set the frequency and on/off duration of the output pulses.



# Arduino Interface Shield

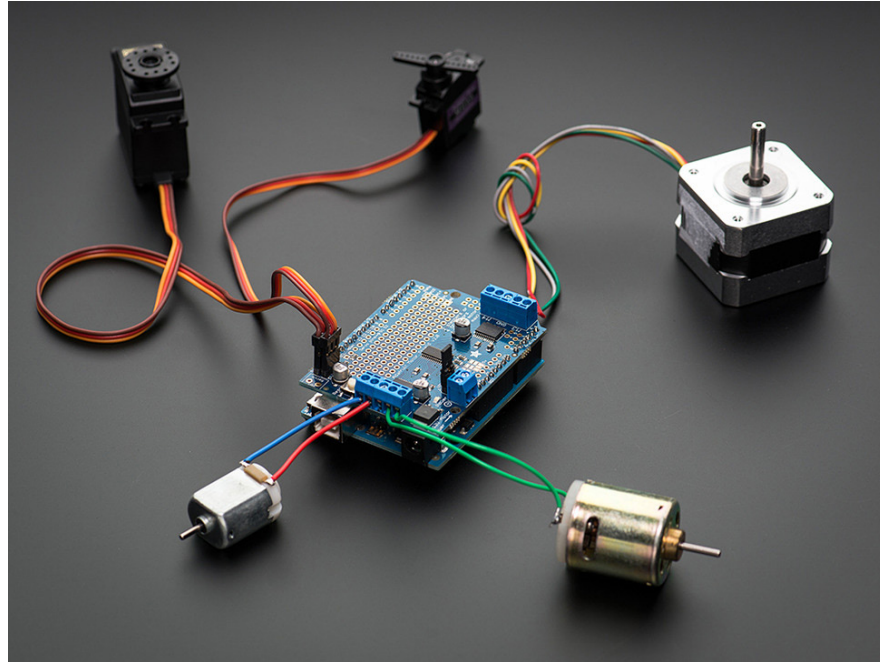

Adafruit Motor/Stepper/Servo Shield  
for Arduino v2 Kit - v2.3

# Motor Direction Control...

## Bipolar H-Bridge

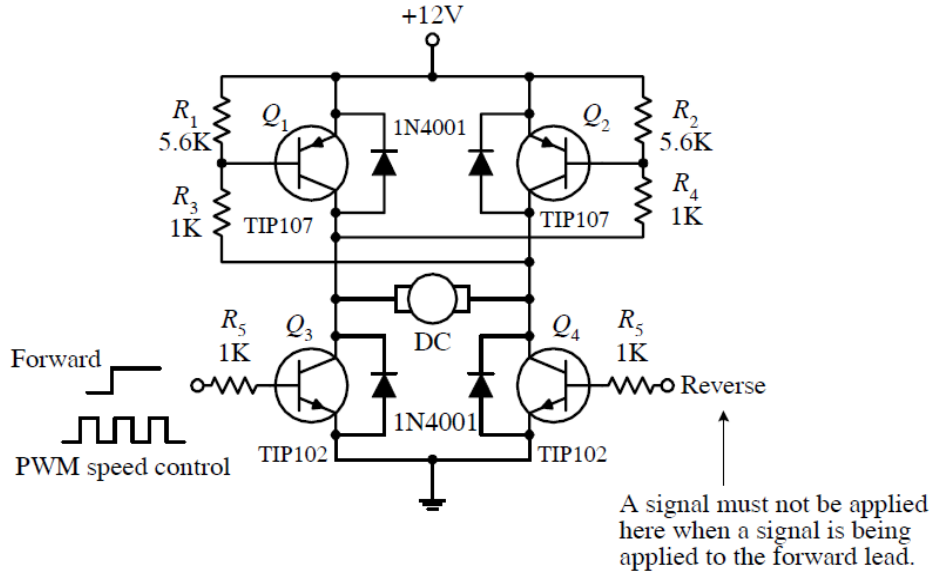

## MOSFET H-Bridge

A HIGH on "Run" pin turns Q7 ON driving its collector LOW and through CD4001b inverts signal to a "HIGH" on gate Q5 turns MOSFET ON, causing motor to run.

A LOW on the Direction pin sets the collector of Q6 HIGH and also Q1's gate HIGH, and through CD4001a, Q4 is ON (Q2 and Q3 are off) creating a current path through Q1, the motor and Q4. When the Direction pin goes HIGH (5V), Q6 switches ON, driving its collector LOW, switching off Q1 and Q4 and turning on Q2 and Q3, creating a reverse current path through Q2, the motor, and Q3.

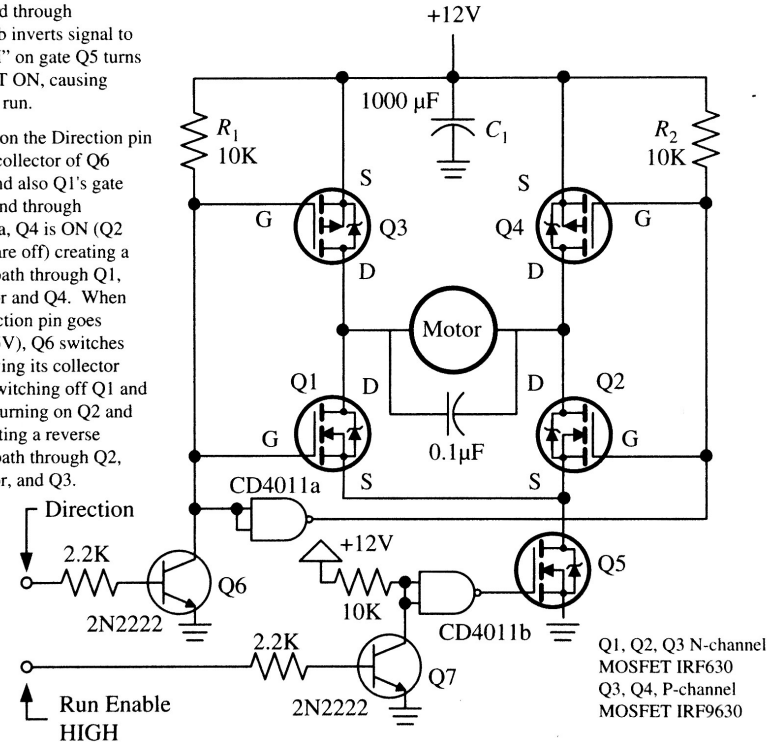

Q1, Q2, Q3 N-channel MOSFET IRF630  
Q3, Q4, P-channel MOSFET IRF9630

# Arduino Interface with an H-Bridge IC...

- The L293NE/SN754410 is a very basic H-bridge. It has two bridges, one on the left side of the chip and one on the right, and can control 2 motors. It can drive up to 1 amp of current, and operate between 4.5V and 36V.

L293NE or SN754410

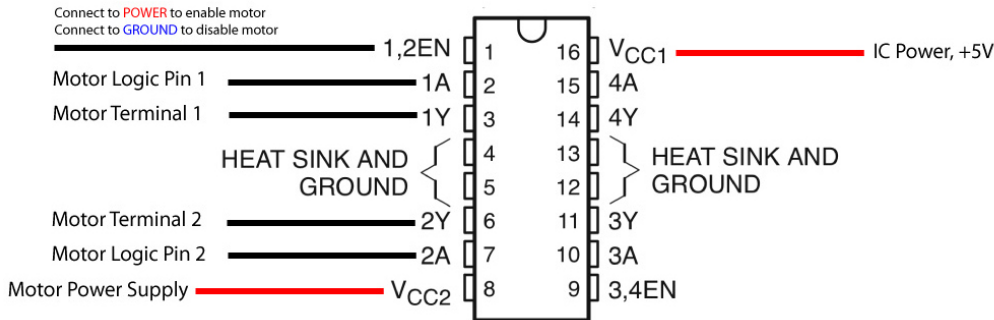

EN	1A	2A	FUNCTION
H	L	H	Turn right
H	H	L	Turn left
H	L	L	Fast motor stop
H	H	H	Fast motor stop
L	X	X	Fast motor stop

L = low, H = high, X = don't care

- Pin 1 (1,2EN) enables and disables the motor whether it is give HIGH or LOW.
- Pin 2 (1A) is a logic pin for motor (input is either HIGH or LOW).
- Pin 3 (1Y) is for one of the motor terminals.
- Pin 4-5 are for ground .
- Pin 6 (2Y) is for the other motor terminal
- Pin 7 (2A) is a logic pin for motor (input is either HIGH or LOW) .
- Pin 8 (VCC2) is the power supply for motor, this should be given the rated voltage of the motor.
- Pin 9-11 are unconnected as if using one motor.
- Pin 12-13 are for ground.
- Pin 14-15 are unconnected .
- Pin 16 (VCC1) is connected to 5V.

Example

# Remote Control Servos



- Voltage: 4.8–6.0 Volts
- Torque: 45.82/56.93 oz-in. (4.8/6.0V)
- Speed: 0.21/0.16 sec/60° (4.8/6.0V)
- Direction: Clockwise/ Pulse Traveling 1500–1900usec
- Rotation: 180°
- Dual Oilite Bushing
- Nylon Gears
- 3-Pole Ferrite Motor
- C1 Standard Spline

Microcontroller Compatible  
Hitec HS-422 Servo



Industrial Servos.  
Image courtesy of Elmo Motion Control.

- ▶ Simple RC servos typically consists of a motor, feedback device (e.g. a potentiometer) and control circuit.
- ▶ An external PWM signal controls the position of the shaft.
- ▶ Angular rotation of an RC servo's shaft is limited to around 180 or 210°.

# *Inside a Servo and a Potentiometer...*

- ▶ Shown are the DC motor, gearbox, potentiometer and control circuit.
- ▶ Using gear reduction, the load and the potentiometer rotate with the motor shaft, within the limits of the potentiometer.

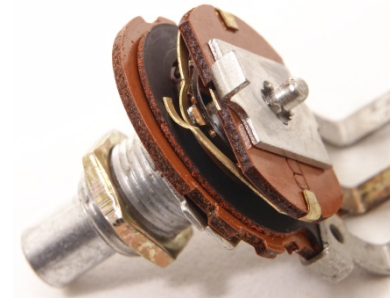
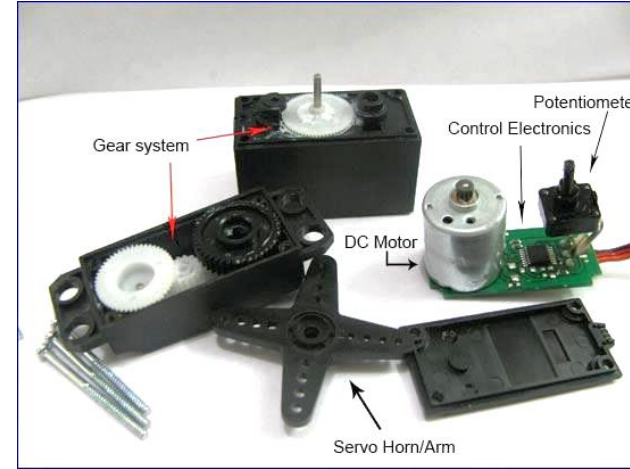

# RC Servo...

A typical servo-control signal and shaft-position response

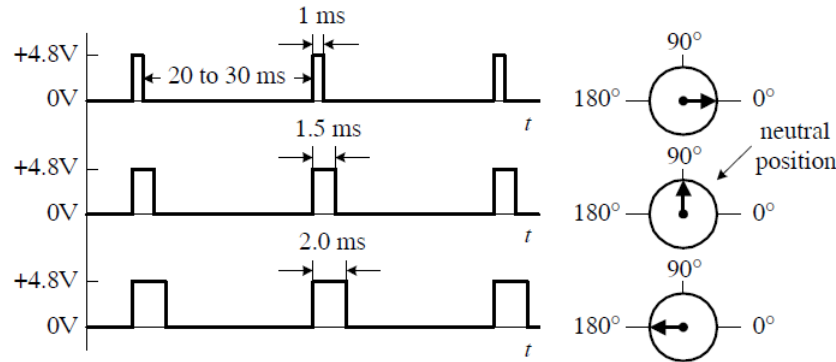

Simple Servo Driver

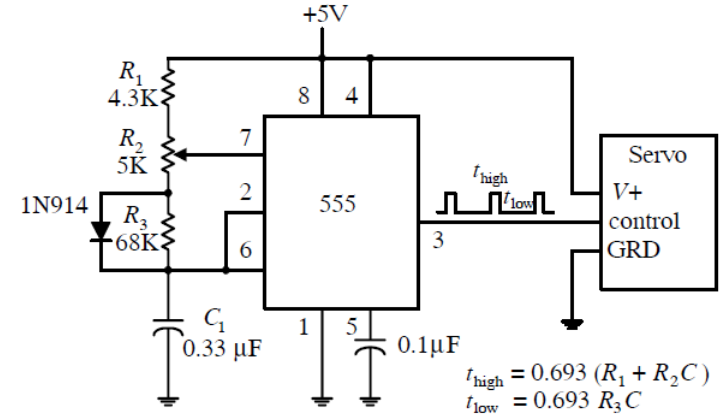

- ▶ An internal potentiometer rotates with the shaft, allowing a measurement of resistance to determine how far the shaft has rotated.
- ▶ The control circuit uses this resistance, along with a pulse-width-modulated input control signal, to drive the motor a specific number of degrees and then hold.
- ▶ When the pulse width is set to 1.5 ms, the servo rotates its shaft to neutral position.
- ▶ Increase or decreasing the width from 1.5 ms will rotate the shaft CCW and CW respectively.

# Stepper Motors & Linear Actuators

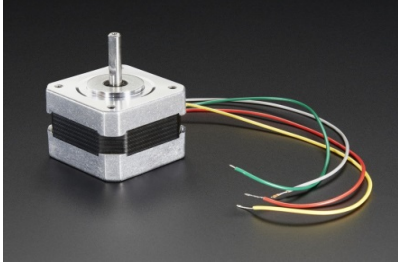

Image courtesy of Adafruit.

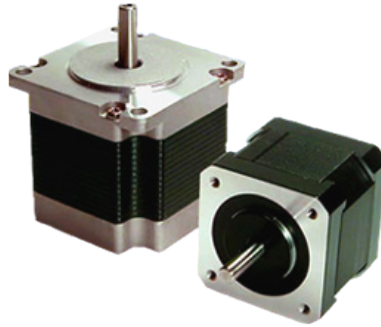

Image courtesy of Osmtec.

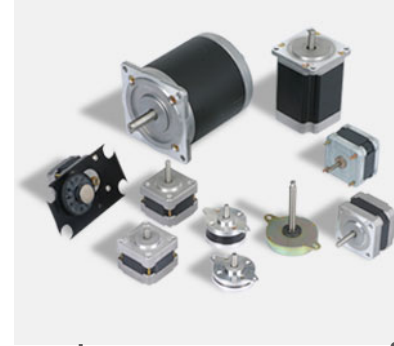

Image courtesy of  
Shinano Kenshi Corp.

- ▶ Brushless motor that rotates with digital pulses– typically 1.8 degrees per pulse.
- ▶ Run at lower speed than DC motors, but with higher torque.
- ▶ Velocity of rotation is related to frequency of the pulses

- ▶ Torque is maintained even at rest.
- ▶ Very good at starting, stopping and reversing direction.
- ▶ No feedback potentiometer is required.
- ▶ “Steps” include:
  - Full step:  $360 \text{ deg} / 200 \text{ step} = 1.8 \text{ deg/step}$ .
  - Half step:  $0.9 \text{ deg/step}$
  - Microstep:  $.007 \text{ deg/step}$
- ▶ Types include variable reluctance, permanent magnet and hybrid.





# *Linear Actuator...*

- ▶ Stepper motors are used in linear motion controllers.
  - The pitch of the lead screw controls the amount of linear distance traveled in one revolution of the screw.
  - Therefore if the lead is 1 IPR, and the stepper motor is 200 SPR, then the resolution  $1/200 = 0.005$  IPS.



Image courtesy of Osmtec.

# *Stepper Motor Driver or Indexer...*



- ▶ The driver takes RS-232 or RS-485 signals from the computer and sends pulses to the stepper.
- ▶ Output control of step frequency, direction, acceleration, deceleration and distance.
- ▶ Additional features include auxiliary input/output for monitoring from external sources such as “Go”, “Home”, “Jog”, or “Limit” switches.

# Fluid Pumps & Flow Sensors

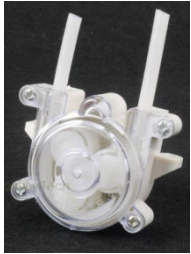

Peristaltic Pumps  
Image courtesy of Adafruit



8v-12v Small DC  
Submersible Water Pump



Hall-Effect Flow Sensor  
(Careful - British Fittings!)

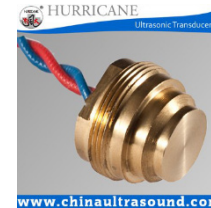

Ultrasonic Flow Sensor

# *Peristaltic Pump...*



- ▶ The pump never touches the fluid which makes this an excellent choice for any food/drink/sterile based pumping.
- ▶ Geared down DC motor with a lot of torque.
- ▶ Silastic tubing is squeezed by revolving rollers.
- ▶ Working Temperature: 0°C – 40 °C.
- ▶ Motor voltage: 12VDC.
- ▶ Motor current: 200–300mA.
- ▶ Flow rate: up to 100 mL/min.
- ▶ Weight: 200 grams.
- ▶ Dimensions: 27mm diameter motor, 72mm total length.
- ▶ Mounting holes: 2.7mm diameter, 50mm center-to-center distance.

# Water Flow Sensor...



- ▶ Mini. Working Voltage: DC 4.5V
- ▶ Max. Working Current: 15mA (DC 5V)
- ▶ Working Voltage: DC 5V~24V
- ▶ Flow Rate Range: 1~30L/min
- ▶ Load Capacity:  $\leq 10\text{mA}$  (DC 5V)
- ▶ Operating Temperature:  $\leq 80^{\circ}\text{C}$
- ▶ Liquid Temperature:  $\leq 120^{\circ}\text{C}$
- ▶ Operating Humidity: 35%~90%RH
- ▶ Water Pressure:  $\leq 1.75\text{MPa}$
- ▶ Storage Temperature:  $-25 \sim + 80^{\circ}\text{C}$
- ▶ Storage Humidity: 25%~95%RH
- ▶ G1&2 Pipe Fittings

# Pneumatic Systems



Image courtesy of Direct Industry

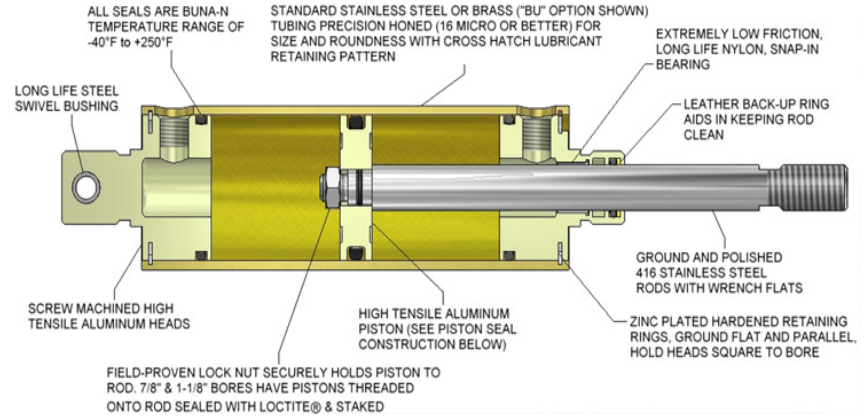
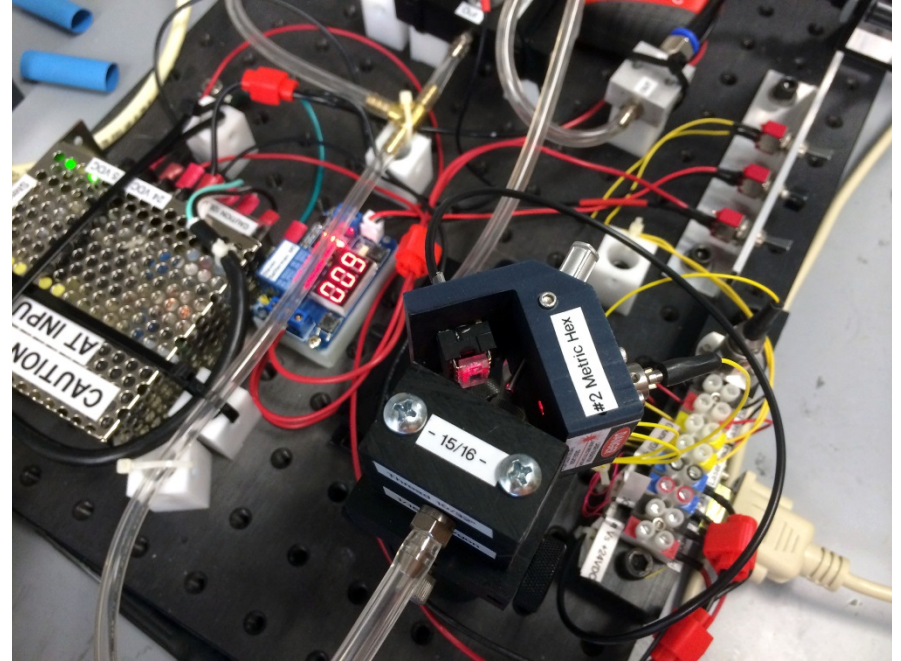
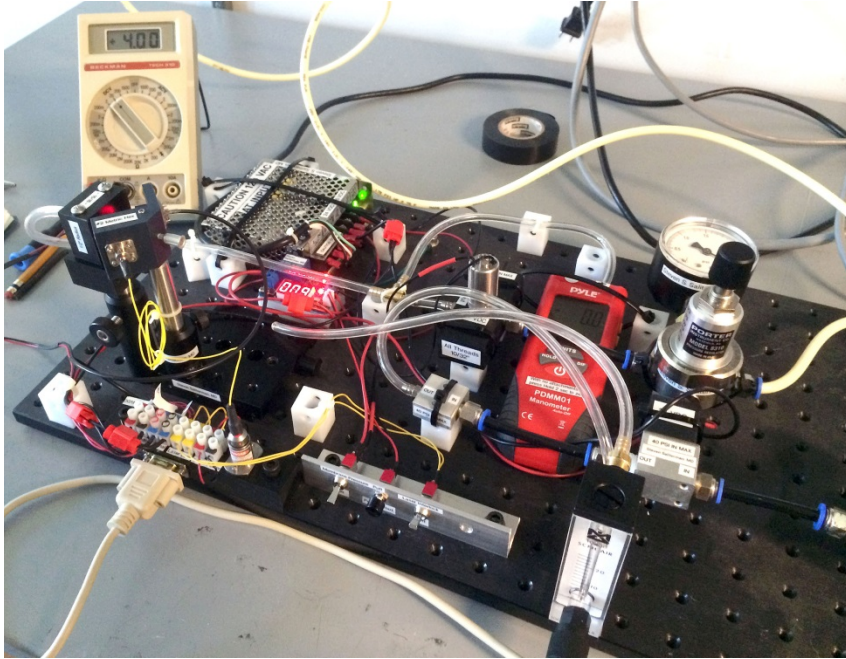

Image courtesy of Allenair



# *Senior Design Project...*



Non-Invasive Intracranial Pressure Measurement Test Apparatus.  
Simulated Cribriform Plate Pressure Pneumatic/Laser Sensor.

# Summary

- ▶ Definition of an actuator.
- ▶ Control signals
- ▶ Relays – electromechanical.
  - Bipolar Junction Transistors
- ▶ Power Switching
  - Silicon Controlled Rectifiers
  - Triac
- ▶ DC motors, RC servos and stepper motors:
  - Unijunction transistor
  - Field effect transistors
- ▶ Stepper motors and linear actuators.
- ▶ Fluid pumps and flow sensors
- ▶ Pneumatic systems.