

# Point of Care White Blood Cell Counter

BMEN 3151 Medical Device Practicum

Claire Mikkelson, Kada Malakowsky, Riley Vaughan, and Roshnee Tarafder

## Clinical Problem

Certain ongoing treatments, such as chemotherapy, require various blood tests to be passed prior to each appointment. The blood tests typically look at hemoglobin, platelets, and white blood cell count. One of the more prevalent preliminary tests for chemotherapy is a white blood cell count. According to Mayo Clinic, white blood cells, more specifically neutrophils, play a key role in fighting infection.<sup>1</sup> Neutrophils need to be within a specific count range in order to prevent further infections, as chemotherapy significantly weakens your immune system. By performing these tests at home, the patients prevent having to visit the clinic if they do not pass the preliminary tests to acquire treatment that day. As medicine is moving towards at home treatment options, the need for this technology is rapidly increasing.

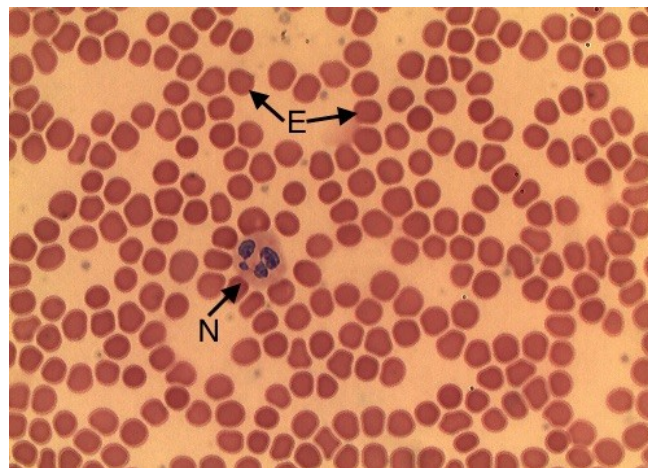

## Medical Device Solution

Our solution to address this problem is a take home kit that would allow patients to easily prepare their own blood sample and photograph the cells to send to their physician prior to their appointment. The kit would be composed of several components such that it is compact, box-like, and easy to use. The blood sample will be acquired from the patient pricking their finger, and will get transferred onto a slide as a smear with an automated smearing device. The smearing device will be powered by a stepper motor to automate the interaction between the two glass slides during a blood smear. A pre-made dye packet will be included within the device to keep the sample collection as simple as possible for the user.

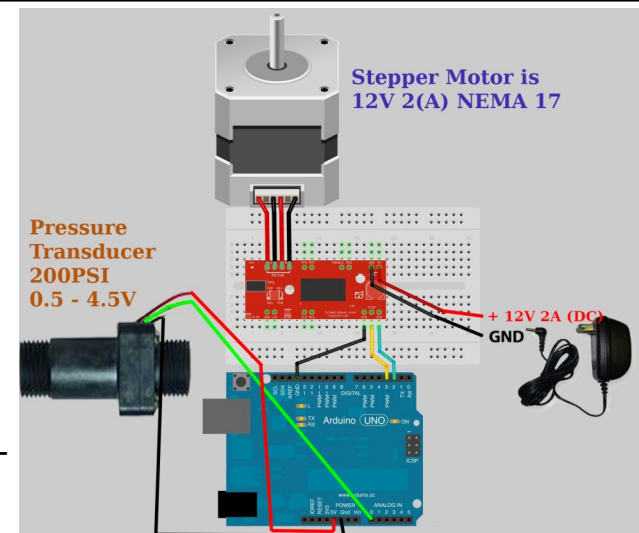

## Needs Statement

**Patients undergoing chemotherapy need a way to self-administer preliminary blood tests at home, specifically a white blood cell count, to avoid getting turned down for routine treatment at a medical facility due to abnormal test results.**

## Market Analysis

According to the CDC: "Each year, about 650,000 cancer patients receive chemotherapy in an outpatient oncology clinic in the United States".<sup>2</sup> With the COVID-19 pandemic jumpstarting the transition to at-home healthcare, the need for these services to be accessible to be performed without a healthcare provider is apparent. "The Global Cancer Chemotherapy Market is expected to grow at a CAGR of around 11.4% from 2020 to 2027 and reach a market value of over US\$ 74.3 Bn by 2027".<sup>3</sup> Our device would decrease the number and length of doctor visits, which will therefore decrease the money spent on treatments for each patient. This would decrease the financial strain and the time commitment required by those undergoing chemotherapy. This device would be a necessity for those who make long commutes to their cancer treatment centers; both the cost of showing up to each appointment, which may include lodging near the facility, and the time involved would be inflated in this case.

## Sources

1. Mayo Foundation for Medical Education and Research. (2021, January 9). *Low blood cell counts: Side effect of cancer treatment*. Mayo Clinic. Retrieved December 5, 2021, from <https://www.mayoclinic.org/diseases-conditions/cancer/in-depth/cancer-treatment/art-20046192>.
2. Centers for Disease Control and Prevention. (2021, November 16). *Information for Health Care Providers*. Centers for Disease Control and Prevention. Retrieved December 5, 2021, from <https://www.cdc.gov/cancer/preventinfections/providers.htm>.
3. Acumen Research and Consulting. (2021, February 8). *Cancer chemotherapy market value anticipated to reach US\$ 74.3 billion by 2027: Acumen research and consulting*. GlobeNewswire News Room. Retrieved December 5, 2021, from <https://www.globenewswire.com/en/news-release/2021/02/08/2171622/0/en/Cancer-Chemotherapy-Market-Value-Anticipated-To-Reach-US-74-3-Billion-By-2027-Acumen-Research-and-Consulting.html>.

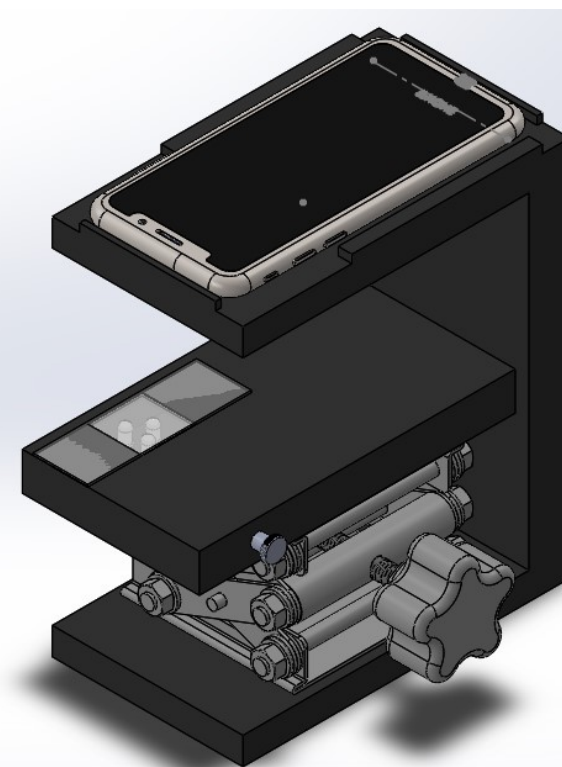

The next component in the kit is a low cost alternative to a traditional microscope. It will contain a phone holder from which the patient can place their phone in line with the camera slot, serving as the magnification device. The device will contain LED lights to illuminate the sample, and the patient will have the option to raise and lower the plane in order to get a clearer image of the sample. Once this clear image has been obtained, the patient will use the phone camera to take a picture of the sample. The photo can then be sent to a physician to analyze and to count the neutrophils in order to estimate the white blood cell count. Future work will include a computer software to automatically analyze the image.

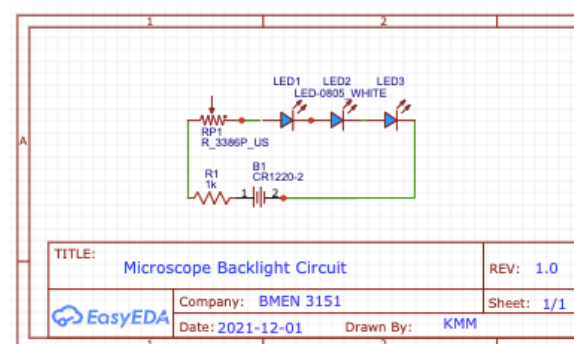

## Team Photo

